



GEDORE

GEDORE 1504 XL



++ TOOL CONTROL +



SERVICE / FEATURES		14 - 17
TOOL TROLLEYS		18 - 29
ACCESSORIES TOOL TROLLEYS		30 - 31
WORKBENCHES		32 - 37
ACCESSORIES WORKBENCHES		38
FOLDING WORKBENCH		38
WORKBENCHES SELF-ASSEMBLY RANGE		39
DRAWER CABINETS		39
TOOL CABINETS		40
USEFUL HELPERS FOR TOOL TROLLEYS / WORKBENCHES		41 - 42
TOOL HOLDERS / TOOL HOOKS		42 - 47
TOOL CHESTS / TOOL BOXES		48 - 49
TOOL CASES / ROLLER TOOL CASES		49 - 51



TOOL ASSORTMENTS MODULES



52 - 93



WORKSHOP EQUIPMENT

GEDORE WORKSHOP FURNITURE...

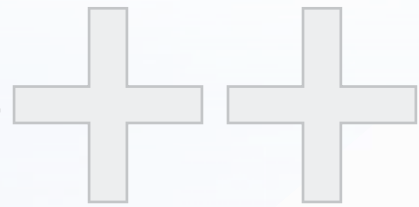

+ BEST-POSSIBLE QUALITY FOR THE HIGHEST DEMANDS PLACED

- ✔ Use of the most up-to-date machinery and environmentally-friendly production processes
- ✔ The basis is tightly-controlled and choice sheet steel
- ✔ Experienced and reliable specialists vouch for precision-like processing
- ✔ Stringent quality checks after each production step ensure a constantly high level
- ✔ Best-possible industrial quality for those extreme levels of constant use and conditions subjected to
- ✔ Professional service up to the development of special customised tools

+ GEDORE WORKSHOP FURNITURE... FORM AND FUNCTION PERFECTION

- ✔ Whether mobile or stationary: indispensable aids, in fact, for the rough-and-ready of workshop routine
- ✔ Extremely robust, scratch and impact-resistant, corrosion-proof and easy to care for
- ✔ Durable and highly resilient with stability of the highest-order
- ✔ Numerous models to reflect use and individual requirements
- ✔ Varied, optional accessories available for flexibly extending all the basic models
- ✔ Specific colours (RAL) and outfits (e.g. stainless steel, oil/acid-resistant etc.) on request



+ GEDORE WORKSHOP FURNITURE... INTELLIGENTLY DESIGNED – DEPENDABLE UNDER EXTREME USE

- ✔ Vertical and horizontal forces are calculated with precision
- ✔ Unloaded weight optimization from a finely-tuned material input
- ✔ Robust, stable 0.88 mm thick sheet steel structure, supporting elements of a 1.00 mm metal thickness, a 2.00mm metal thickness for the heavy-duty chassis
- ✔ Precision spot welding ensures components stay permanently fixed
- ✔ Tool trolleys have it all with their special GEDORE chassis and GEDORE heavy-duty wheels
- ✔ Durable and highly resilient with stability of the highest-order



GEDORE WORKSHOP FURNITURE... + ... TIDY LOOK, UNCLUTTERED AND ALWAYS AT HAND

- ✔ Ready to be used straight after delivery: simply unpack and screw on the manoeuvring handle
- ✔ Whether a mobile or stationary guardian of tidiness: each tool has its own place here
- ✔ Modular arrangement systems make daily routine that much easier (visual check/tool missing)
- ✔ Compact tool assortments make selection easier
- ✔ Customised equipment/tool sets in module systems and/or trolleys/benches in company design/colours



+ THE GEDORE CHARACTER

Individual drawer locking (not applicable to 2003)

- In addition to the central locking, each drawer has its own separate latch to prevent unwanted opening, when being moved
- The latch is automatically released by a tilting bar when the drawer is opened
- The single latch automatically engages when the drawer closes

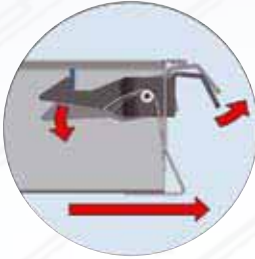

Central locking

- One central lock for all drawers and doors
- Safe and easy handling

Ball-bearing drawer slides

- The ball-bearing drawer slides ensure safe and easy sliding of the drawers, even when loaded to full capacity
- Full extension improves access

Load capacity

- The load capacity of the drawers is 40 kg
- The combined weight of our two mechanics' tool sets, S 1004 M and S 1007 M, is 40 kg
- One drawer could hold the full weight of all 250 tools!
- Models 2003, 2004, 2005, 1502, 1504, 1504 XL: The bottom drawer is designed as heavy-duty drawer, load capacity 60 kg

Square perforation 9 x 33 mm

- The square perforation in the side walls enable quick access to frequently used tools
- GEDORE holders and trays are simply clipped in

Heel protection

- All-round heel protection by rounded edges on the underside allows the tool trolley or workbench to be safely pulled or pushed

The GEDORE chassis

- The trapezoidal GEDORE chassis uniformly distributes the applied forces.
- The axle is mounted on triple bearings and is securely connected to the trapezoid.
- The third, central bearing prevents the axle bending under load.
- The special axle design ensures that the GEDORE high-performance rollers always roll on the full faces of their treads.
- Even under full load, the rollers retain their smooth running properties and cannot shed their tyres.
- Vertical and horizontal forces are absorbed by the positive-fit trapezoidal design.

Smooth running and high-performance wheels

- The GEDORE smooth running and high-performance wheels keep, even under maximum load, the following features: Smooth running, track-keeping and manoeuvrability!

Total braking system

- Prevents unwanted movement and turning of the wheel
- Ensures safe parking of the tool trolley or workbench

Impact protection

- The vertical or horizontal impact protection protects the tool trolley and anything it comes into contact with from damage
- It also protects other equipment in the workshop or vehicles from inadvertent contact

Powder coating

- GEDORIT blue and GEDORIT silver are the short names for the two types of powder paint, specially developed for GEDORE
- This coating method guarantees a high level of corrosion protection, combined with tough scratch resistance
- Powder coating is kind on the environment. Unused powder is reclaimed in the plant. No solvent is used
- Special colours available on request

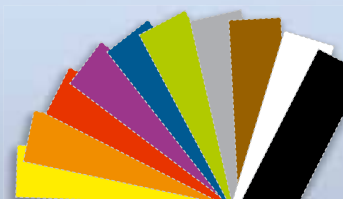













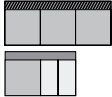





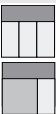

+ SELECTION AID - TOOL TROLLEYS

Type / Pattern	Trolley body					Chassis				Drawers					
	Load capacity (kg)	Central locking system	ABS working platform with compartments/protective edge	Impact protection	for car boot transportation	Wide-track chassis / heavy-duty (S)	GEDORE heavy-duty wheels	2x fixed castors (mm)	2x swivel castors (mm) incl. 1x total brake	Number	extendable to both sides	Max. load capacity per drawer (kg)	Single safeguard	fully extendable	Drawer volume Compatibility - modules
2005 500	●	●	●	●		S	●	200	125	6 - 10		40/60	●	●	
2004 500	●	●	●	●		S	●	200	125	5 - 10		40/60	●	●	
2003 500	●	●	●	●		S	●	200	125	7		40/60	●	●	
3000 400	●	●	●	●		B	●	200	125	7		40	●	●	
2545 330	●	●	●	●			●	200	125	7		35	●	●	
2525 330	●	●	●	●			●	140	100	7		40	●	●	
2535 250	●	●	●	●	●		●	140	100	4 plus large capacity drawer		22	●	●	
1585 300	●		●	●	●		●	140	100	6		40	●	●	
3010 120/220	●		●	●	●		●	140	100	3 plus large capacity drawer	●	22			
2000 300	●		●	●		B	●	140	100	5 plus large capacity drawer	●	22			
2500 300	●		●	●		B	●	140	100	8		40	●	●	
1580 300	●		●	●			●	140	100	4 plus large capacity drawer	●	22			
1578 200	●		●	●			●	140	100	6	●	22			



+ SELECTION AID - WORK BENCHES

Type / Pattern	Body							Storage space			Drawers				
	Height (mm)	with chassis - mobile	Mobile load capacity (kg)	Static load capacity (kg)	Central locking system	Wooden worktop (mm)	Heel protection edge	Wide-track chassis / heavy-duty (S)	Storage compartment with door/ storage compartment open (o)	including the back	Number	Max. load capacity per drawer (kg)	Single safeguard	fully extendable	Drawer volume Compatibility - modules
MOBILE															
1505 	900	●	500	1000	●	40	●	S	●		5	40	●		
1504 XL 	985	●	500	700	●	30	●	S	●		7 (6+1XL)	40/60	●	●	
1504 	985	●	500	700	●	30	●	S	●		6 - 10	40/60	●	●	
BR 1504 	985	●	500	700	●	30	●	S	●	●	7	40/60	●	●	
1502 	870	●	500	700	●	25	●		(o) open		6	40	●	●	
STATIONARY															
BR 1500 LH 	900			1000	●	40	●		●	●	5	40	●	●	
B 1500 L 	900			1000	●	40	●		●		5	40	●	●	
B1510 	840			250	●	40					0 - 4	35	●	●	
B1511 	840			250	●	40					0 - 4	35	●	●	
B 1525 	810			500			●								

**ES modules****CT modules**

85 - 93



2005

TOOL TROLLEY

- ✔ Working platform in ABS with 3 compartments for small parts
- ✔ With handle for easy pushing, pulling and turning
- ✔ Wide drawers (W 640 x D 400 mm)
- ✔ Drawers fully extendable, removable
- ✔ Single-hand operation with safety locking which prevents the drawers from opening when in motion
- ✔ Ball bearings
- ✔ Drawers individually partitionable, delivery includes length- (LD) and crosswise dividers (CD), see table
- ✔ Please order distance module 1500 ED-70 XL for fixing the modules
- ✔ Bottom drawer designed as heavy-duty drawer
- ✔ Load capacity per drawer 40 kg, bottom heavy-duty drawer 60 kg
- ✔ Both side walls with square perforation to fix torque wrenches or other long tools and accessories
- ✔ Central locking with cylinder lock
- ✔ Heel protection and all-round impact protection
- ✔ GEDORE heavy-duty chassis with high-performance wheels on roller bearings, with 2 fixed castors Ø 200 mm and 2 swivel castors Ø 125 mm, one with total brake
- ✔ Total load capacity 500 kg
- ✔ Dimensions: H 985 x W 775 x D 435 mm
- ✔ In GEDORIT blue, drawers GEDORIT silver, top black
- ✔ Delivery without tools and accessories
- ✔ Optional accessories: Tool chest 2430, rear panel R 2004 L or RB 2004 L, Wood plate 2004 HP

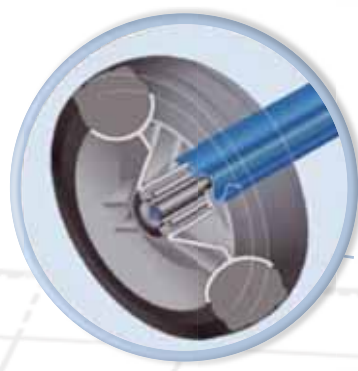

Code	No.		LD	CD	H	W	D	
1803018	2005 0511	5x type 1, H = 67 mm 1x type 2, H = 137 mm 1x type 3, H = 207 mm	10x	2x	985	775	435	93.0
2003546	2005 0321	3x type 1, H = 67 mm 2x type 2, H = 137 mm 1x type 3, H = 207 mm	6x	2x	985	775	435	89.0
2003554	2005 0701	7x type 1, H = 67 mm 2x type 2, H = 137 mm 1x type 3, H = 207 mm	10x	2x	985	775	435	92.0
2003562	2005 0810	8x type 1, H = 67 mm 1x type 2, H = 137 mm	15x	3x	985	775	435	99.0

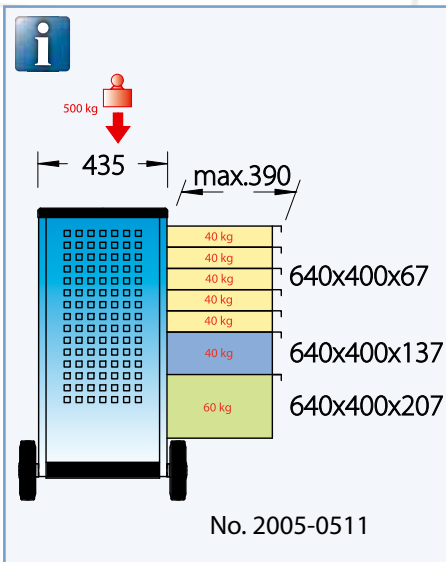

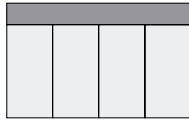
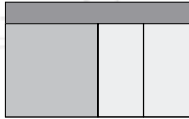
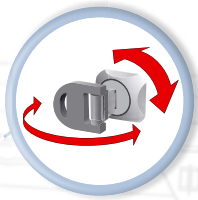

Optional accessories

➔ 2004 HP



31



➔ 1500 ES • 1500 CT



85
-
93

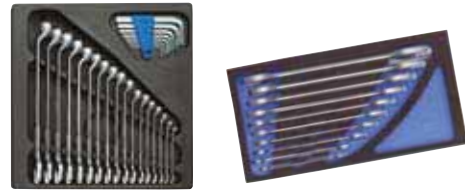

➔ 2430



30



➔ RB 2004 L



31

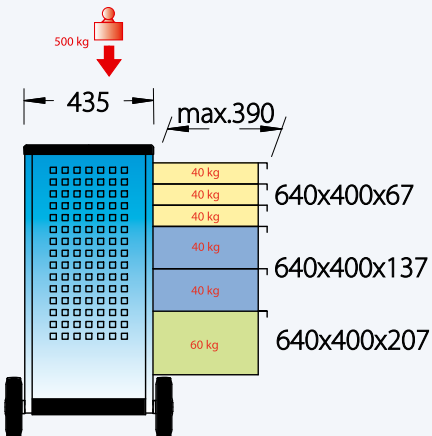

No. 2005-0321

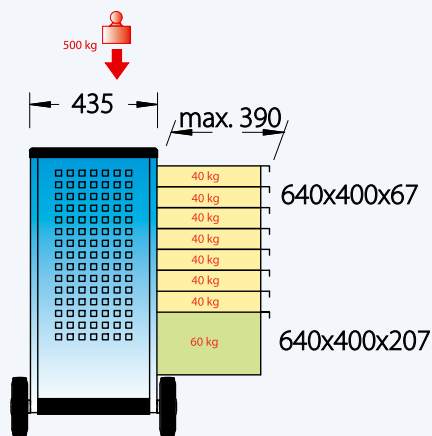

No. 2005-0701

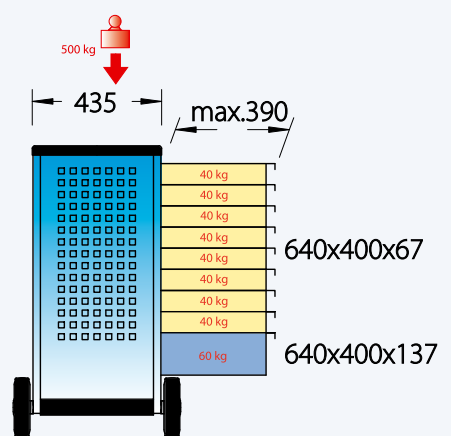

No. 2005-0810



2004

TOOL TROLLEY

- ✔ Working platform in ABS with 3 compartments for small parts
- ✔ With handle for easy pushing, pulling and turning
- ✔ Drawers fully extendable, removable
- ✔ Single-hand operation with safety locking which prevents the drawers from opening when in motion
- ✔ Ball bearings
- ✔ Drawers individually partitionable, delivery includes length- (LD) and crosswise dividers (CD), see table
- ✔ Bottom drawer designed as heavy-duty drawer
- ✔ Load capacity per drawer 40 kg, bottom heavy-duty drawer 60 kg (apart from 2004 1000)
- ✔ Storage compartment on the handle side with perforated sheet 9 x 33 mm to fix accessories
- ✔ Compartment door lockable with central locking
- ✔ Four removable drawers for small parts
- ✔ Central locking with cylinder lock
- ✔ Heel protection and all-round impact protection
- ✔ GEDORE heavy-duty chassis with high-performance wheels on roller bearings, with 2 fixed castors Ø 200 mm and 2 swivel castors Ø 125 mm, one with total brake
- ✔ Total load capacity 500 kg
- ✔ Dimensions: H 985 x W 775 x D 435 mm
- ✔ In GEDORIT blue, drawers GEDORIT silver, top black
- ✔ Delivery without tools and accessories
- ✔ Optional accessories: Tool chest 2430, Rear panel R 2004 L or RB 2004 L, Wood plate 2004 HP

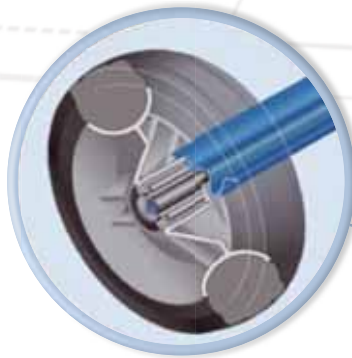

Code	No.		LD	CD	H	W	D	↕
1640690	2004 1000	10x type 1, H = 67 mm	15x	3x	985	775	435	94.0
1640704	2004 0810	8x type 1, H = 67 mm 1x type 2, H = 137 mm	15x	3x	985	775	435	91.0
1640712	2004 0701	7x type 1, H = 67 mm 1x type 3, H = 207 mm	10x	2x	985	775	435	86.0
1640720	2004 0620	6x type 1, H = 67 mm 2x type 2, H = 137 mm	10x	2x	985	775	435	88.0
1640739	2004 0511	5x type 1, H = 67 mm 1x type 2, H = 137 mm 1x type 3, H = 207 mm	10x	2x	985	775	435	84.0
1640755	2004 0321	3x type 1, H = 67 mm 2x type 2, H = 137 mm 1x type 3, H = 207 mm	6x	2x	985	775	435	82.0
1640763	2004 0131	1x type 1, H = 67 mm 3x type 2, H = 137 mm 1x type 3, H = 207 mm	3x	2x	985	775	435	75.0

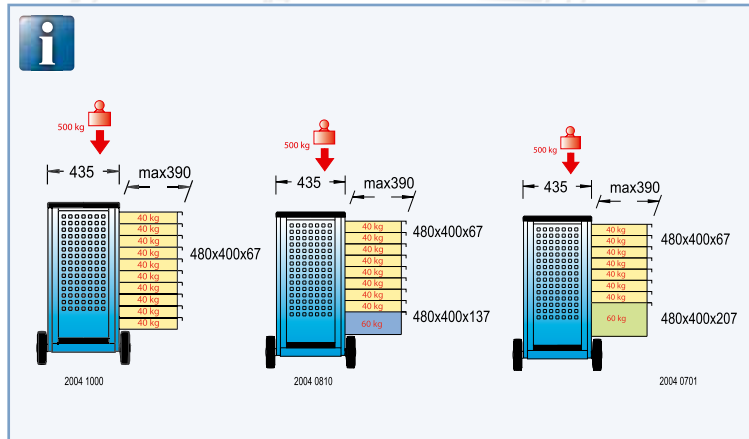

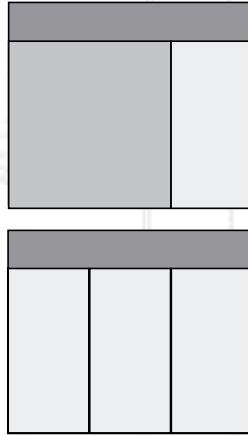
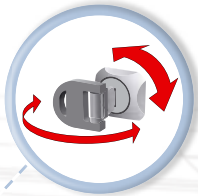

Optional accessories

→ 2004 HP

31



→ R 2004 L

31



→ 2430

30



→ 1500 ES

85 - 89



→ 1500 BL

41

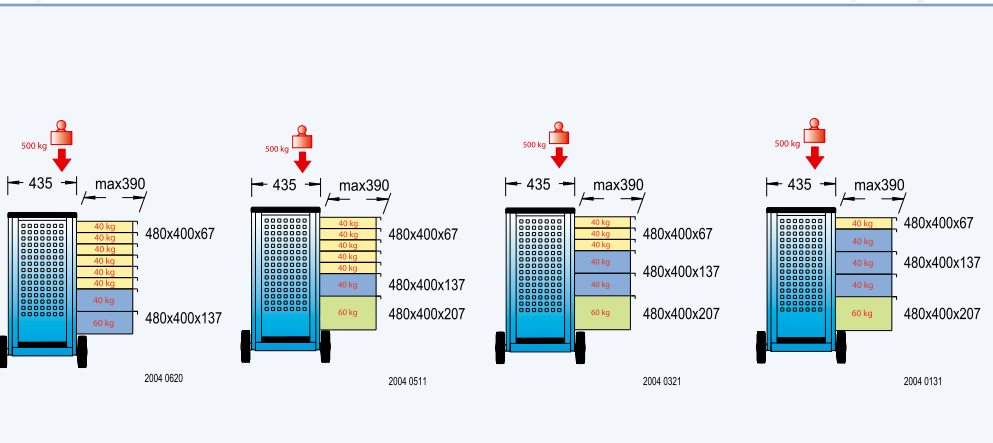



2003

TOOL TROLLEY with 7 drawers

- ✔ Working platform in ABS with 3 compartments for small parts
- ✔ With handle for easy pushing, pulling and turning
- ✔ Drawers fully extendable, removable
- ✔ Single-hand safety locking
- ✔ Ball bearings
- ✔ Drawers individually partitionable, delivery includes 10 length- and 2 crosswise dividers
- ✔ Supplied 2 distance modules 1500 ED-70 K
- ✔ Bottom drawer designed as heavy-duty drawer
- ✔ Load capacity per drawer 40 kg, bottom heavy-duty drawer 60 kg
- ✔ Storage compartment on the handle side with perforated sheet 9 x 33 mm to fix accessories
- ✔ Compartment door lockable with central locking
- ✔ Four removable drawers for small parts
- ✔ Central locking with cylinder lock
- ✔ Heel protection and all-round impact protection
- ✔ GEDORE heavy-duty chassis with high-performance wheels on roller bearings, with 2 fixed castors Ø 200 mm and 2 swivel castors Ø 125 mm, one with total brake
- ✔ Total load capacity 500 kg
- ✔ Dimensions: H 985 x W 775 x D 435 mm
- ✔ In GEDORIT blue, drawers GEDORIT silver, top black
- ✔ Delivery without tools
- ✔ Optional accessories: Tool chest 2430, Rear panel R 2004 L or RB 2004 L, Wood plate 2004 HP

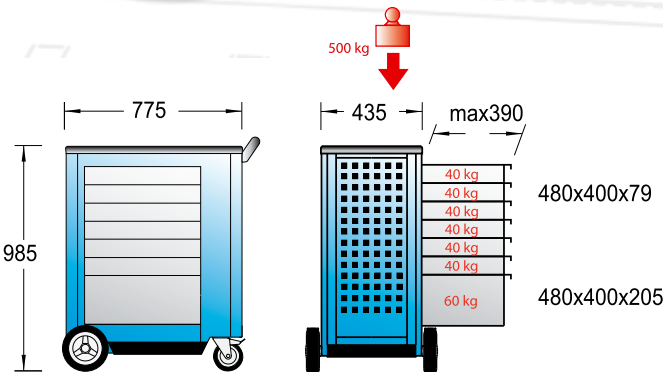
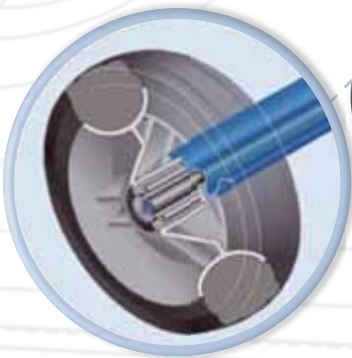
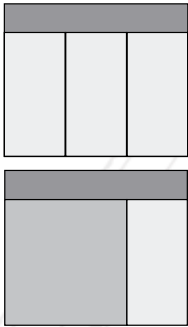
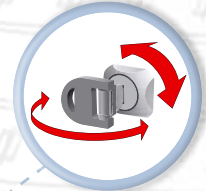

Code	No.	H	W	D	Wt
6630930	2003	985	775	435	82.0



3000

TOOL TROLLEY TANTO with 7 drawers

- ✔ Ideal for the utility vehicle sector
- ✔ Strong and manoeuvrable - rear axle steering ensures dynamic steering properties
- ✔ Can be turned on the spot, easily maneuverable, especially in narrow corridors
- ✔ Working platform in ABS with 4 compartments for incidental parts
- ✔ Drawers fully extendable, removable, ball bearings
- ✔ Drawers 1-6 individually partitionable, delivery includes 8 length- and 2 crosswise dividers and 2 anti-slip mats
- ✔ Single-hand operation with safety locking which prevents the drawers from opening when in motion
- ✔ Load capacity per drawer 40 kg
- ✔ Large capacity drawer for bulky parts
- ✔ Deep rear shelf with perforated wall 9 x 33 mm to fix accessories
- ✔ Central locking for padlock
- ✔ With heel protection and safety shock absorber
- ✔ GEDORE wide-track chassis with heavy-duty wheels on roller bearings, with 2 fixed castors Ø 200 mm and 2 swivel castors Ø 125 mm, one with total brake
- ✔ Total load capacity 400 kg
- ✔ Dimensions: H 920 x W 585 x D 485 mm
- ✔ In GEDORIT blue, drawers GEDORIT silver, top black
- ✔ Delivery without tools
- ✔ Optional accessories: Tool set S 1022, door element 1500 H 14, modules 1500 ES + CT, trays and much more besides

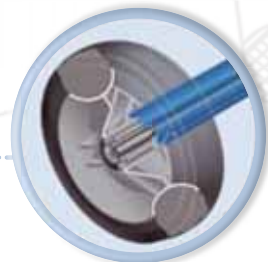
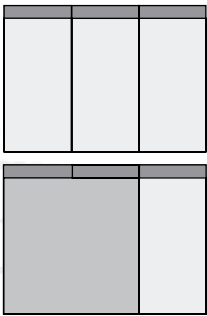
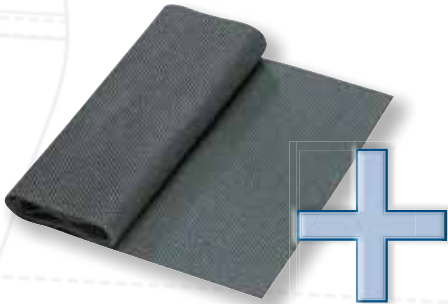

Code	No.	H	W	D	
6624880	3000	920	585	485	67.0

Optional accessories

➔ 1500 CT

90 - 93

➔ 1500 H 9

43

➔ 1500 H 14

31



2545 - 2546 - 2550

TOOL TROLLEY AND TOOL CHEST

2545 Tool trolley

- ✔ Working platform in ABS with 4 compartments for small parts
- ✔ With handle for easy pushing, pulling and turning
- ✔ 7 drawers fully extendable
- ✔ Single-hand operation with safety locking which prevents the drawers from opening when in motion
- ✔ Drawers individually partitionable, delivery includes 10 length- and 2 crosswise dividers
- ✔ Load capacity per drawer 35 kg
- ✔ 3 perforated side walls to fit with accessories
- ✔ Rear side with space for storage
- ✔ Central locking with cylinder lock
- ✔ With heel protection and vertical impact protection
- ✔ GEDORE heavy-duty chassis with high-performance wheels on roller bearings, with 2 fixed castors Ø 200 mm and 2 swivel castors Ø 125 mm, one with total brake
- ✔ Total load capacity 330 kg
- ✔ Dimensions: H 955 x W 705 x D 485 mm
- ✔ In GEDORIT blue, drawers GEDORIT silver, top black

2546 Tool chest

- ✔ Ribbed bottom lining
- ✔ 4 drawers fully extendable
- ✔ Drawers individually partitionable, delivery includes 6 length- and 2 crosswise dividers
- ✔ Roomy storage compartment with document partition
- ✔ Pneumatic soft opening and closing of lid
- ✔ Total load capacity 120 kg
- ✔ Dimensions: H 495 x W 705 x D 485 mm
- ✔ In GEDORIT blue, drawers GEDORIT silver, top black
- ✔ Delivery without tools

- ✔ **2550** consisting of tool trolley 2545 and tool chest 2546

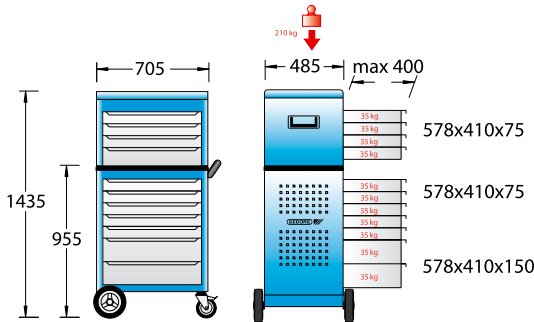
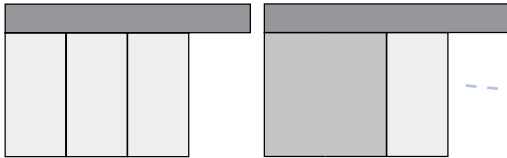

No. 2550

Code	No.	Description	LD	CD	H	W	D	↕
1942980	2545	Tool trolley with 7 drawers	10x	2x	955	705	485	77.0
1942999	2546	Tool chest with 4 drawers	6x	2x	495	705	485	45.0
1942972	2550	Tool trolley with tool chest	16x	4x	1435	705	485	122.0

Optional accessories

➔ **1500 CT**

90 - 93

➔ **1500 ES**

85 - 89

➔ **2525 HP**

31

➔ **1500 H**

42 - 45

➔ **1500 H 13**

41

➔ **1500 H 9 • H 10**

43



2525-520

TOOL TROLLEY with 7 drawers

- Working platform in ABS with 3 compartments for small parts
- With handle for easy pushing, pulling and turning
- Drawers fully extendable, removable, 1-5 individually partitionable
- Delivery includes 8 length- and 2 crosswise dividers
- Single-hand operation with safety locking which prevents the drawers from opening when in motion
- Load capacity per drawer 40 kg
- 2 perforated side walls, mounted inwards to fit with accessories
- Delivery includes tray for small parts and 10-piece hook assortment
- Central locking with cylinder lock
- With heel protection, sides with vertical impact protection
- GEDORE chassis with high-performance wheels on roller bearings, with 2 fixed castors Ø 140 mm and 2 swivel castors Ø 100 mm, one with total brake
- Total load capacity 330 kg
- Dimensions: H 965 x W 720 x D 395 mm
- In GEDORIT blue, drawers GEDORIT silver, top black
- Delivery without tools
- Optional accessory: Wood plate no. 2525 HP

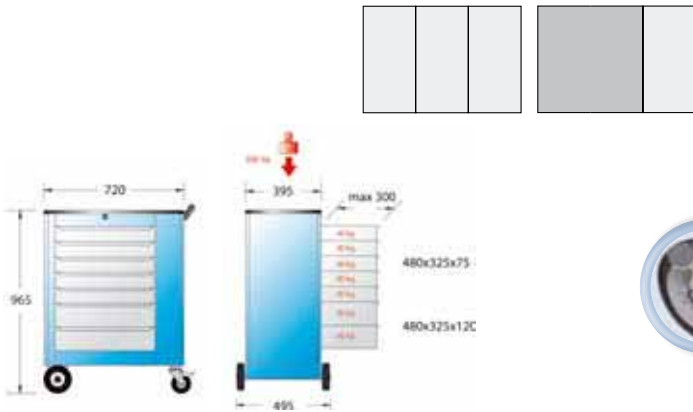

Code	No.	H	W	D	
1587102	2525-520	965	720	395	67.0



2535

TOOL TROLLEY DUO with 4 drawers

- Working platform in ABS with 3 compartments for small parts
- Drawers fully extendable, removable
- Single-hand operation with safety locking which prevents the drawers from opening when in motion
- Drawers individually partitionable, delivery includes length- (LD) and crosswise dividers (CD), see table
- Load capacity per drawer 40 kg
- Large storage compartment
- Separate locking for top and bottom of mobile toolchest with two identical cylinder locks
- Top and bottom of mobile toolchest joined by quick-action latches for easy separation. Top and bottom each with two carry handles
- With heel protection, sides with vertical impact protection
- GEDORE chassis with high-performance wheels on roller bearings, with 2 fixed castors Ø 140 mm and 2 swivel castors Ø 100 mm, one with total brake
- Total load capacity 330 kg
- Dimensions: H 930 x W 630 x D 390 mm
- In GEDORIT blue, drawers GEDORIT silver, top black
- Delivery without tools

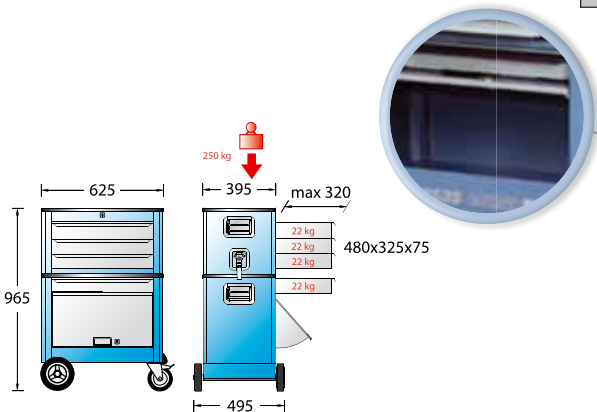

Code	No.	LD	CD	H	W	D	
1892495	2535	4x	2x	965	625	395	50.0
1906445	2535 SMA	3x	2x	350	625	395	27.0
1904167	2535 SMW	1x	-	635	625	395	23.0



No. 2535



1585

3-CHEST TOOL TROLLEY MODULAR SYSTEM

- ✔ When tool chests 1430 and 1431 are stacked on it, the base 1432 becomes the mobile high-capacity trolley 1585
- ✔ The base 1432 can of course also be combined with various tool chests, e.g. 1433-1072 ES
- ✔ With plug-in lockable push handle, also suitable for lifting the trolley
- ✔ A perforated metal sheet at the handle permits equipping the trolley with tools or parts for installation
- ✔ 1432 with ribbed bottom lining, central locking for padlock
- ✔ Drawers fully extendable, with single-hand safety locking
- ✔ Load capacity per drawer 40 kg
- ✔ With heel and impact protection
- ✔ GEDORE chassis with high-performance wheels on roller bearings, with 2 fixed castors Ø 140 mm and 2 swivel castors Ø 100 mm, one with total brake
- ✔ Total load capacity 300 kg
- ✔ Dimensions: H 1060 x W 660 x D 400 mm
- ✔ In GEDORIT blue, drawers GEDORIT silver, top black
- ✔ Delivery without tools



No. 1585
(No. 1430 + 1431 + 1432)



No. 1432 + 1430



No. 1432

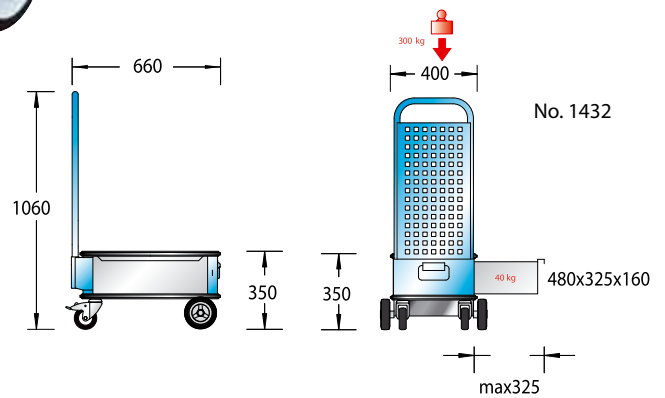
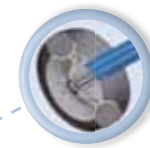
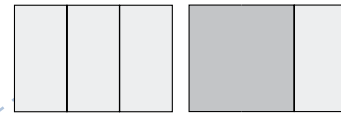

No. 1432

Code	No.	Description	H	W	D	LD	CD	CD	CD
6624290	1585	3-Chest tool trolley without tools	1060	660	400	8x	4x	64.0	
6618130	1430	Tool chest with 3 drawers	305	625	400	6x	2x	26.0	
6615030	1431	Tool chest with 2 drawers	305	625	400	2x	2x	23.0	
6615620	1432	Tool chest with mobile base	1060	660	400	-	-	24.0	
5801550	1582 HG	Hook assortment, 20 pieces						0.7	

Optional accessories

1433

30

1500 CT

90 - 93

1500 H 13

41



3010

TOOL TROLLEY VARIO with lowering mechanism

- Working platform with ribbed bottom lining
- Lowering mechanism with single-button operation
- Drawers open either side
- Ball bearings, with middle and end catches
- Drawers individually partitionable, delivery includes 6 length- and 2 crosswise dividers
- Load capacity per drawer 22 kg
- Central locking when lowered, secured by padlock
- Heel protection and all-round impact protection
- GEDORE chassis with high-performance wheels on roller bearings, with 2 fixed castors Ø 140 mm and 2 swivel castors Ø 100 mm, one with total brake
- Lifts automatically with up to 25 kg load
- Automatic lock, to produce a sturdy working surface with over 120 kg load capacity
- When lowered, total load capacity over 220 kg
- Dimensions: H 900 x W 625 x D 400 mm
- In GEDORIT blue, drawers GEDORIT silver, top black
- Delivery without tools



MAX

MIN

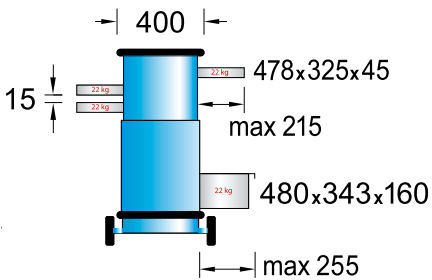
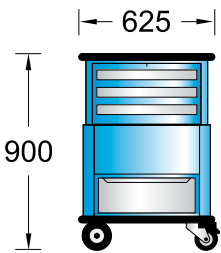

Code	No.	H	W	D	
6625260	3010	900	625	400	42.0

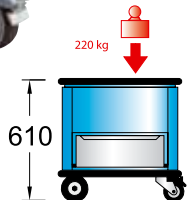



2000

TOOL TROLLEY with 5 drawers

- ✔ Working platform with ribbed bottom lining
- ✔ With handle for easy pushing, pulling and turning
- ✔ Drawers open either side, ball bearing catches, with middle and end catches
- ✔ Drawers individually partitionable, delivery includes 10 length- and 2 crosswise dividers
- ✔ Load capacity per drawer 22 kg
- ✔ Double sided metal shutters to secure the whole internal space
- ✔ Central locking with cylinder lock
- ✔ Heel protection and all-round impact protection
- ✔ GEDORE wide-track chassis with high-performance wheels on roller bearings, with 2 fixed castors Ø 140 mm and 2 swivel castors Ø 100 mm, one with total brake
- ✔ Trapezoid shape for extra stability, wheels mounted internally
- ✔ Total load capacity 300 kg
- ✔ Dimensions: H 930 x W 625 x D 400/545 mm
- ✔ In GEDORIT blue, drawers GEDORIT silver, top black
- ✔ Optional accessories: Top tool chests 1430, 1431, 1433-1072 ES, Wood plate 2000 HP

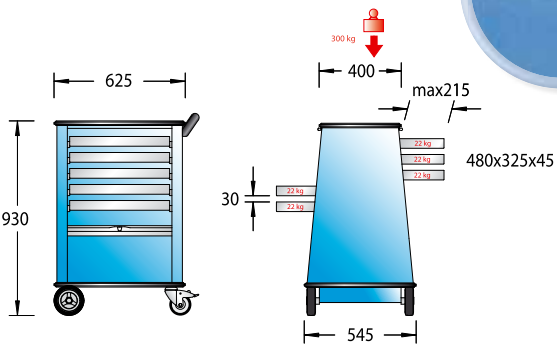
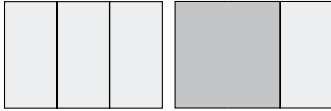

Code	No.	H	W	D ₁	D ₂	W
6627710	2000	930	625	400	545	47.0

2500

TOOL TROLLEY with 8 drawers

- ✔ Working platform with ribbed bottom lining
- ✔ With handle for easy pushing, pulling and turning
- ✔ Drawers fully extendable, removable, ball-catch bearings, with middle and end catches
- ✔ Single-hand safety locking
- ✔ Drawers individually partitionable, delivery includes 10 length- and 2 crosswise dividers
- ✔ Load capacity per drawer 40 kg
- ✔ Central locking with cylinder lock
- ✔ Heel protection and all-round impact protection
- ✔ GEDORE wide-track chassis with high-performance wheels on roller bearings, with 2 fixed castors Ø 140 mm and 2 swivel castors Ø 100 mm, one with total brake
- ✔ Trapezoid shape for extra stability, wheels mounted internally
- ✔ Total load capacity 300 kg
- ✔ Dimensions: H 960 x W 625 x D 400/545 mm
- ✔ Optional accessories: Top tool chests 1430, 1431, 1433-1072 ES, Wood plate 2000 HP

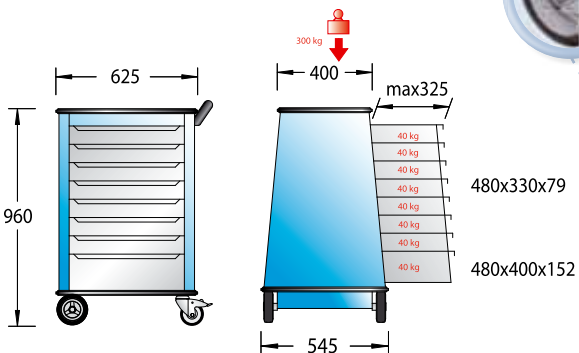

Code	No.	H	W	D ₁	D ₂	W
6171720	2500	960	625	400	545	64.0



1580

TOOL TROLLEY with 4 drawers

- Working platform with ribbed bottom lining
- With handle for easy pushing, pulling and turning
- Drawers open either side
- Ball bearings, with middle and end catches
- Drawers individually partitionable, delivery includes 8 length- and 2 crosswise dividers
- Load capacity per drawer 22 kg
- Deep storage at base
- Both sides with square perforation
- Central locking with cylinder lock
- Double sided metal shutters to secure the whole internal space
- Heel protection and all-round impact protection
- GEDORE chassis with high-performance wheels on roller bearings, with 2 fixed castors Ø 140 mm and 2 swivel castors Ø 100 mm, one with total brake
- Total load capacity 300 kg
- Dimensions: H 930 x W 625 x D 400 mm
- In GEDORIT blue, drawers GEDORIT silver, top black
- Delivery without tools
- Optional accessories: Top tool chests 1430, 1431, 1433-1072 ES, Wood plate 2000 HP, Additional drawer KSF 1580

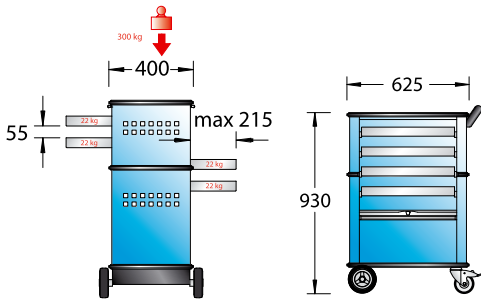
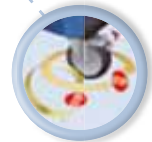
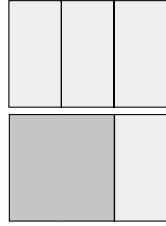

Code	No.	H	W	D	W
6627550	1580	930	625	400	40.0

1578

TOOL TROLLEY with 6 drawers

- Working platform in ABS with 3 compartments for small parts
- With handle for easy pushing, pulling and turning
- Drawers open either side
- Drawers individually partitionable, delivery includes 6 length- and 2 crosswise dividers
- Load capacity per drawer 22 kg
- Central locking with cylinder lock
- With heel protection
- GEDORE chassis with high-performance wheels on roller bearings, with 2 fixed castors Ø 140 mm and 2 swivel castors Ø 100 mm, one with total brake
- Total load capacity 200 kg
- Dimensions: H 930 x W 605 x D 375 mm
- In GEDORIT blue, drawers GEDORIT silver, top black

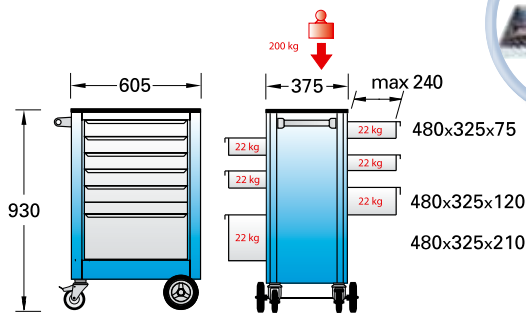
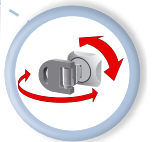
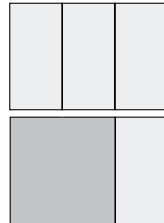

Code	No.	H	W	D	W
9018140	1578	930	605	375	43.5

Optional accessories

KSF 1580



31

2000 HP



31

1430 • 1431



30



TOP TOOL CHESTS

1430

TOOL CHEST

- Designed particularly as top box for trolleys 1580, 1585, 2000, 2500, 3010
- With three partitionable drawers, supplied with 6 lengthwise and 2 crosswise dividers
- Drawers run smoothly on guides with ball bearings fully extendable
- Load capacity per drawer 40 kg
- Central locking with hasp for padlock
- Rubber mat, and rubber protection around the edge
- In GEDORIT blue, drawers GEDORIT silver
- Dimensions: H 305 x W 625 x D 400 mm

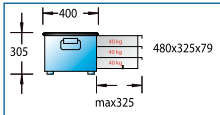
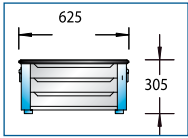

Code	No.	H	W	D	Weight
6618130	1430	305	625	400	26.0

1431

TOOL CHEST

- Designed particularly as top box for trolleys 1580, 1585, 2000, 2500, 3010
- With 2 drawers, drawers run smoothly on guides with ball bearings, fully extendable
- One partitionable drawer, supplied with 2 lengthwise and 2 crosswise dividers
- Load capacity per drawer 40 kg
- Central locking with hasp for padlock
- Rubber mat, and rubber protection around the edge
- In GEDORIT blue, drawers GEDORIT silver
- Dimensions: H 305 x W 625 x D 400 mm

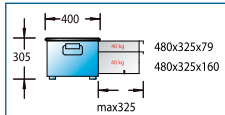
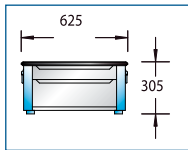

Code	No.	H	W	D	Weight
6615030	1431	305	625	400	23.0

2430

TOOL CHEST

- Designed particularly as top box for trolleys 2003, 2004, 2005
- Working platform in ABS with 3 compartments for small parts
- Three drawers individually partitionable, delivery includes 6 length- and 2 crosswise dividers
- Each drawer suitable to take 4 pieces of 1/3 tool modules no. 1500 ES / 1500 CT
- Drawer size: W 640 x D 400 x H 67 mm
- Drawers fully extendable, removable
- Single-hand operation with safety locking which prevents the drawers from opening when in motion
- Load capacity per drawer 40 kg
- Central locking with cylinder lock
- In GEDORIT blue, drawers GEDORIT silver
- Dimensions: H 345 x W 775 x D 435 mm
- Optional accessory: Wood plate no. 2004 HP

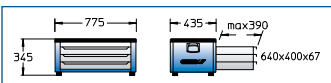

Code	No.	H	W	D	Weight
1888927	2430	345	775	435	23.0

2546

TOOL CHEST

- Ribbed bottom lining
- Four drawers fully extendable
- Drawers individually partitionable, delivery includes 6 length- and 2 crosswise dividers
- Load capacity per drawer 35 kg
- Roomy storage compartment with document partition
- Pneumatic soft opening and closing of lid
- Total load capacity 120 kg
- Dimensions: H 495 x W 705 x D 485 mm
- In GEDORIT blue, drawers GEDORIT silver, top black

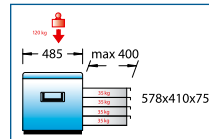
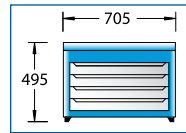

Code	No.	H	W	D	Weight	Quantity
1942999	2546	495	705	485	45.0	1

1433-1072 ES

TOOL CHEST for mobile use

- Tool chest 1433 L including 3 modular tool boxes 1072 ES-1500 L
- Open at front, central locking with turnlock fastener for a padlock
- Particularly suitable for use in combination with chassis 1432 for mobile use
- In GEDORIT blue
- Dimensions: H 310 x W 605 x D 375 mm

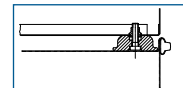
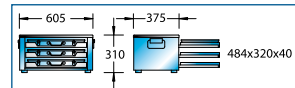

Code	No.	H	W	D	Weight
1482483	1433-1072 ES	310	605	375	20.4
6627200	1433 L	310	605	375	16.0

1072 ES

TOOL MODULE EMPTY

- For tool modules 1500 ES
- May be individually equipped with two or three tool modules
- Foam rubber firmly glued to lid
- Suitable as spare part in tool chest 1433 L
- Sturdy sheet steel, in GEDORIT blue
- Dimensions: W 478 x D 313 x H 70 mm
- Delivery without tools



Code	No.	W	D	H	Weight
6602990	1072 ES-1500 L	480	330	70	3.3



1072 K

TOOL BOX

- Sturdy sheet steel, in GEDORIT blue
- With deep-drawn plastic insert with 19 compartments
- Fits into tool chest 1433 L
- Dimensions: W 480 x D 330 x H 70 mm
- (Ill. similar)



Code	No.	W	D	H	
1920049	1072 K-19	480	330	70	3.6

R 2004 L

REAR PANEL

- Can be attached to 2003, 2004, 2005
- The complete loaded rear wall can be simply lowered
- Automatically raised by two gas springs
- Neat arrangement of tools on square perforation 9 x 33 mm
- Central locking with cylinder lock
- Delivery without tools

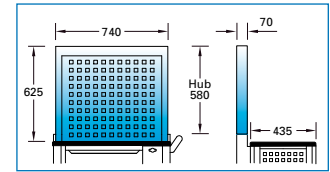

Code	No.	H	W	D	
1446169	R 2004 L	768	770	116	25.0

RB 2004 L

REAR PANEL

- Can be attached to 2003, 2004 and 2005
- Square perforation 9 x 33 mm



Code	No.	H	W	D	
1933302	RB 2004 L	700	665	15	5.8

1500 H 14

DOOR ELEMENT for TANTO 3000

- For later installation
- The free space in the rear can be enclosed with this and secured with the cylinder lock installed
- 3000 TANTO models from 1998 on are set up for this installation, assembly materials are supplied
- Suitable trays 1500 H 9-75 and 1500 H 10-75
- In GEDORIT silver
- Delivery without tools



Code	No.	
5809880	1500 H 14	5.9

ACCESSORIES FOR TOOL TROLLEYS

2004 HP

WOOD PLATE

- Multiplex beech wood
- For tool trolleys 2003, 2004 and 2005 and tool chest 2430
- To fit in the plastic top, 30 mm thick, to get an additional work surface



Code	No.	mm	W	D	
1446967	2004 HP	30	590	410	5.0

2000 HP

WOOD PLATE

- Multiplex beech wood
- For tool trolleys 1580, 1585, 2000, 2500, 3010, and tool chests 1430, 1431, 1433

Code	No.	mm	W	D	
1785567	2000 HP				

2525 HP

WOOD PLATE

- Multiplex beech wood
- For tool trolley 2525
- To fit in the plastic top, 20 mm thick, to get an additional work surface

Code	No.	mm	W	D	
2082578	2525 HP	20	550	375	4.0

1500 H 7

TRAY

- Will fit on 1580, 1585, 2000, 2500
- A useful tray to increase the working surface, captive coupling to the trolley
- Load capacity approx. 5 kg
- In GEDORIT blue with rubber mat

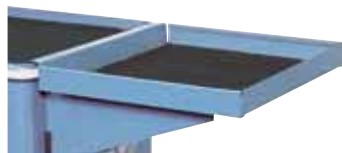

Code	No.	H	W	D		
5792030	1500 H 7	30	370	300	1.6	1

KSF 1580

ADDITIONAL DRAWER

- Will fit the drawers of GEDORE tool trolley 1580
- With bearings, mounting pieces and mounting manual
- Up to 4 additional drawers can be fitted
- In GEDORIT silver



Code	No.	H	W	D	
6624610	KSF 1580	24	420	325	2.2

WORKBENCHES

1505

MOBILE WORKBENCH

- ✔ Ergonomic working height
- ✔ 40 mm thick multiplex beech wood worktop, surface additionally protected by linseed oil varnish
- ✔ Five drawers, extendable up to 505 mm, with single-hand safety locking
- ✔ Drawers individually partitionable, delivery includes 9 length- and 9 crosswise dividers as well as 2 distance modules no. 1500 ED-70 K
- ✔ Ball bearings
- ✔ Load capacity per drawer 40 kg
- ✔ Large, lockable cupboard with shelf
- ✔ Central locking with cylinder lock
- ✔ With heel protection
- ✔ GEDORE Jumbo heavy-duty chassis with independent wheel suspension - sturdy and mobile
- ✔ With hydraulic raising mechanism - just lift the pull handle
- ✔ High floor clearance for easy, safe movement and absolutely stable standing
- ✔ Static load capacity 1000 kg, 500 kg when mobile
- ✔ Dimensions: H 900 x W 1100 x D 652 mm
- ✔ Model S with vice no. 411-150
- ✔ In GEDORIT blue, drawers GEDORIT silver
- ✔ Delivery without tools
- ✔ Prepared for mounting rear panel no. R 1504 L

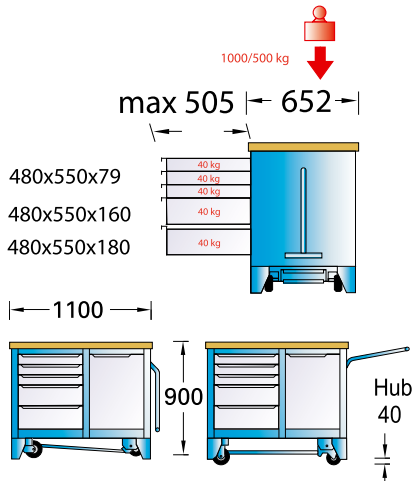
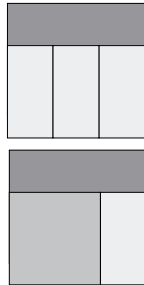
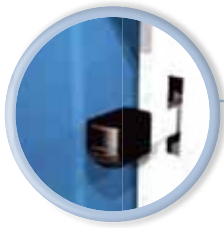

Code	No.	Description	mm [D]	H	W	D	mm [D]
6621780	1505	Mobile workbench	40	900	1100	652	138.0
6621860	1505 S	Mobile workbench with vice	40	900	1100	652	156.5

Optional accessories

<p>R 1504 L</p>	<p>38</p>	<p>1500 BL</p>	<p>41</p>	<p>1500 H 13</p>	<p>41</p>
<p>411-125</p>	<p>466</p>	<p>1500 H</p>	<p>42 - 45</p>	<p>1500 ES / CT</p>	<p>85 - 93</p>



1504 XL

MOBILE WORKBENCH EXTRA WIDTH

- 30 mm thick multiplex beech wood worktop, surface additionally protected by linseed oil varnish
- One extra large drawer for long tools or 6 tool modules (1/3 modules)
- Drawers fully extendable
- Single-hand operation with safety locking which prevents the drawers from opening when in motion
- Ball bearings
- Drawers individually partitionable, delivery includes 10 length- and 2 crosswise dividers
- Bottom drawer designed as heavy-duty drawer
- Load capacity per drawer 40 kg, bottom heavy-duty drawer 60 kg
- Large usable storage space with lockable door
- Central locking for cylinder lock
- With heel protection
- GEDORE heavy-duty chassis with high-performance wheels on roller bearings, with 2 fixed castors Ø 200 mm and 2 swivel castors Ø 125 mm with total brake
- Static load capacity 700 kg, 500 kg when mobile
- Dimensions: H 985 x W 1250 x D 550 mm
- In GEDORIT blue, drawers GEDORIT silver
- Delivery without tools
- Optional accessories: Rear panel R 1504 XL-L

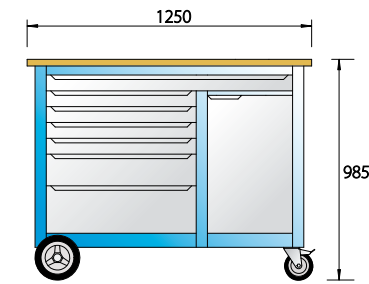
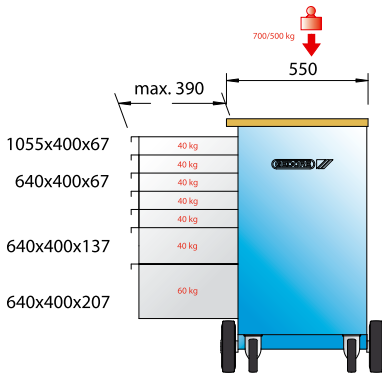
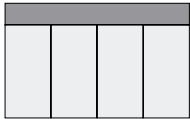
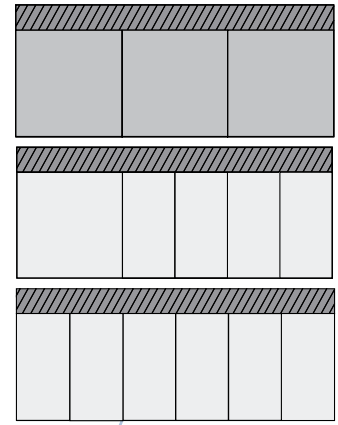

Code	No.		H	W	D	
1988468	1504 XL	1x type XL, H = 67 mm, W = 1055 mm 4x type 1, H = 67 mm 1x type 2, H = 137 mm 1x type 3, H = 207 mm	985	1250	550	1200



R 1504 XL-L



38

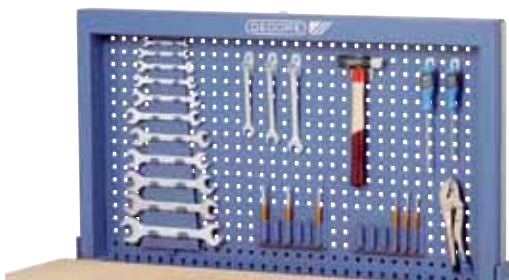



1504

MOBILE WORKBENCH

- ▶ 30 mm thick multiplex beech wood worktop, surface additionally protected by linseed oil varnish
- ▶ Five different drawer combinations
- ▶ Drawers fully extendable
- ▶ Single-hand operation with safety locking which prevents the drawers from opening when in motion
- ▶ Ball bearings
- ▶ Drawers individually partitionable, delivery includes length- (LD) and crosswise dividers (CD), see table, as well as 2 distance modules no. 1500 ED-70 K
- ▶ Bottom drawer designed as heavy-duty drawer
- ▶ Load capacity per drawer 40 kg, bottom heavy-duty drawer 60 kg (apart from 1504 1000)
- ▶ Large usable storage space with lockable door
- ▶ Central locking with cylinder lock
- ▶ With heel protection
- ▶ GEDORE heavy-duty chassis with high-performance wheels on roller bearings, with 2 fixed castors Ø 200 mm and 2 swivel castors Ø 125 mm with total brake
- ▶ Static load capacity 700 kg, 500 kg when mobile
- ▶ Dimensions: H 985 x W 1100 x D 550 mm
- ▶ Model S with vice no. 411-125
- ▶ In GEDORIT blue, drawers GEDORIT silver
- ▶ Delivery without tools
- ▶ Optional fold-down rear panel no. R 1504 L can be fitted

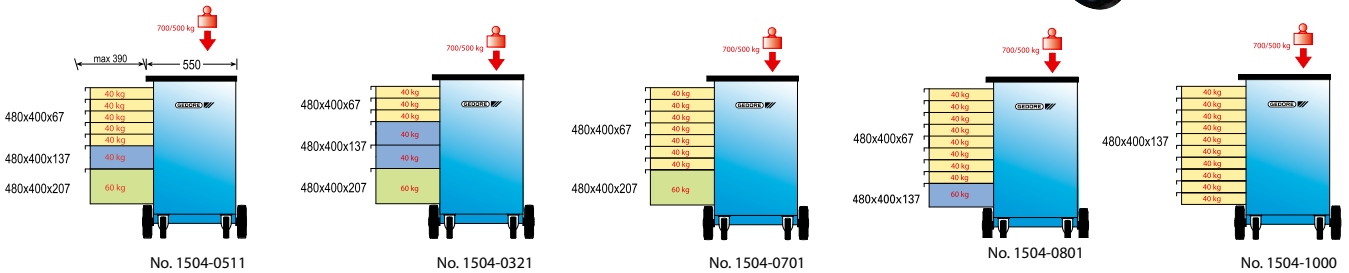
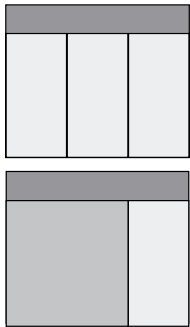

Code	No.	LD	CD	Description	mm	
6622830	1504 0511	5x type 1, H = 67 mm 1x type 2, H = 137 mm 1x type 3, H = 207 mm	10x	2x	Mobile workbench with 7 drawers	100.0
6623050	1504 0511 S	5x type 1, H = 67 mm 1x type 2, H = 137 mm 1x type 3, H = 207 mm	10x	2x	Mobile workbench with 7 drawers and vice	102.2
1814958	1504 0321	3x type 1, H = 67 mm 2x type 2, H = 137 mm 1x type 3, H = 207 mm	6x	2x	Mobile workbench with 6 drawers	96.0
1814931	1504 0701	7x type 1, H = 67 mm 1x type 3, H = 207 mm	10x	2x	Mobile workbench with 8 drawers	99.0
1814923	1504 0810	8x type 1, H = 67 mm 1x type 2, H = 137 mm	15x	3x	Mobile workbench with 9 drawers	106.0
1814915	1504 1000	10x type 1, H = 67 mm	15x	3x	Mobile workbench with 10 drawers	110.0

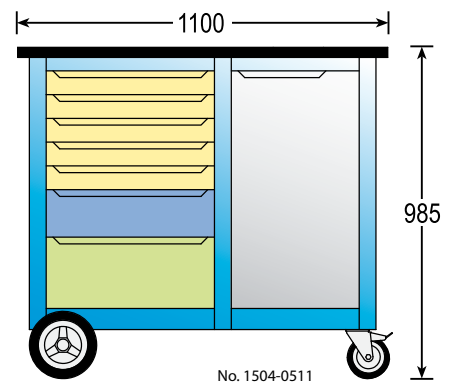

**BR 1504****MOBILE WORKBENCH with self raising rear panel**

- ✔ Multiplex beech wood worktop, surface additionally protected by linseed oil varnish
- ✔ Drawers fully extendable
- ✔ Single-hand operation with safety locking which prevents the drawers from opening when in motion
- ✔ Ball bearings
- ✔ Drawers individually partitionable, delivery includes 10 length- and 2 crosswise dividers as well as 2 distance modules no. 1500 ED-70 K
- ✔ Bottom drawer designed as heavy-duty drawer
- ✔ Load capacity per drawer 40 kg, bottom heavy-duty drawer 60 kg
- ✔ Large usable storage space with lockable door
- ✔ With installed rear panel R 1504
- ✔ Automatically raised by 2 gas springs
- ✔ The complete loaded rear wall can be simply lowered
- ✔ Central locking with cylinder lock
- ✔ With heel protection
- ✔ GEDORE heavy-duty chassis with high-performance wheels on roller bearings, with 2 fixed castors Ø 200 mm and 2 swivel castors Ø 125 mm with total brake
- ✔ Static load capacity 700 kg, 500 kg when mobile
- ✔ Dimensions: H 985 x W 1100 x D 550 mm
- ✔ Model LH with hook assortment no. 1504 HG
- ✔ Model S with vice no. 411-125
- ✔ In GEDORIT blue, drawers GEDORIT silver
- ✔ Delivery without tools

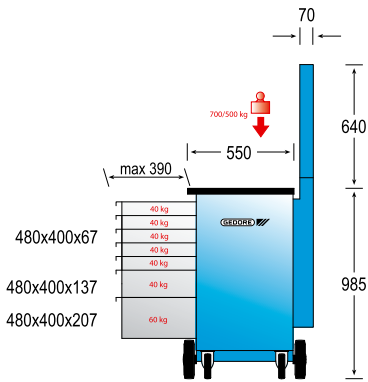
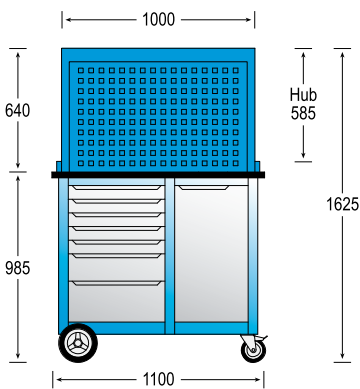

BR1504_0511

Code	No.	Description	mm	H	W	D	
6624450	BR 1504 0511 L	Workbench with rear panel	30	985	1100	550	128.0
6623990	BR 1504 0511 LH	Workbench with rear panel + hook assortment	30	985	1100	550	130.0
6624370	BR 1504 0511 S	Workbench with rear panel + vice	30	985	1100	550	130.0

Optional accessories

411-125

466

1500 BL

41

1500 ES / CT

85 - 93



1502

MOBILE WORKBENCH

- ✔ 25 mm thick multiplex beech wood worktop, surface additionally protected by linseed oil varnish
- ✔ Six drawers fully extendable
- ✔ Single-hand safety locking
- ✔ Ball bearings
- ✔ Drawers individually partitionable, delivery includes 10 length- and 2 crosswise dividers as well as 2 distance modules no. 1500 ED-70 K
- ✔ Bottom drawer designed as heavy-duty drawer
- ✔ Load capacity per drawer 40 kg, bottom heavy-duty drawer 60 kg
- ✔ Large, easily-accessible spaces for bulky parts
- ✔ Central locking with cylinder lock
- ✔ With heel protection
- ✔ GEDORE heavy-duty chassis with high-performance wheels on roller bearings, with 2 fixed castors Ø 200 mm and 2 swivel castors Ø 125 mm with total brake
- ✔ Static load capacity 700 kg, 500 kg when mobile
- ✔ Dimensions: H 875 x W 950 x D 550 mm
- ✔ Model S with vice no. 409
- ✔ In GEDORIT blue, drawers GEDORIT silver
- ✔ Delivery without tools

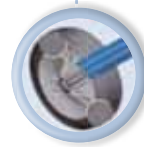
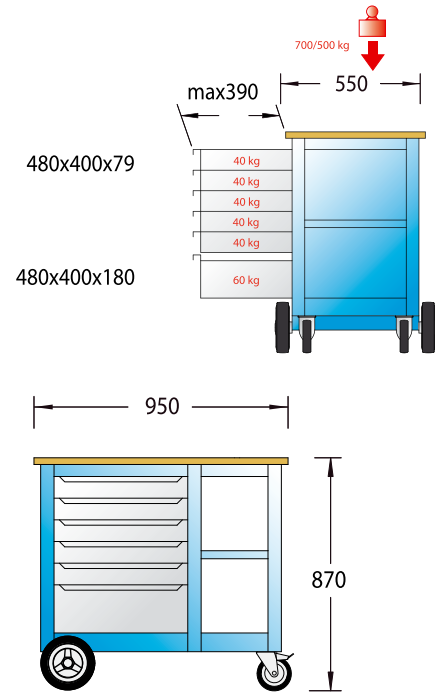
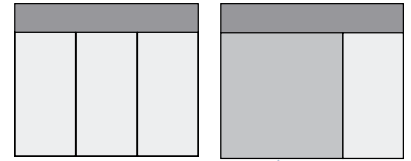

Code	No.	Description	mm	H	W	D	W
6620540	1502	Mobile workbench	25	875	950	550	78.0
6620620	1502 S	Mobile workbench with vice	25	875	950	550	85.0





BR 1500 LH

WORKBENCH WITH TOOL CABINET

B 1500 L

- 40 mm thick multiplex beech wood worktop, surface additionally protected by linseed oil varnish
- Five drawers, extendable up to 505 mm, individually partitionable, delivery includes 9 length- and 9 crosswise dividers
- Drawers removable
- Load capacity per drawer 40 kg
- Open space for storage, secured with strong metal shutter
- Separate locking of drawers and shutter by cylinder locks
- With heel protection
- Total load capacity 2000 kg
- Dimensions: H 900 x W 2000 x D 875 mm
- In GEDORIT blue, drawers GEDORIT silver

R 1500 LH

- Sheet steel construction
- With metal shutter lockable by cylinder lock
- Perforated rear to take fittings for any choice of assortment
- With hook assortment 1500 HS 23
- Dimensions: H 890 x W 1810 x D 170 mm
- In GEDORIT blue, shutter GEDORIT silver

BR 1500 LH Consisting of workbench B 1500 L and tool cabinet R 1500 LH

Delivery without tools

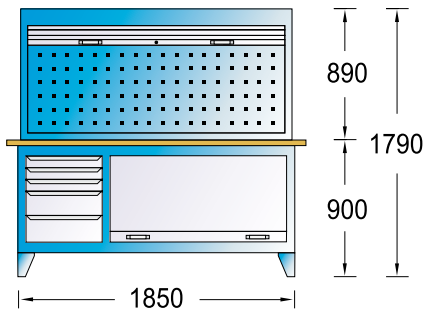
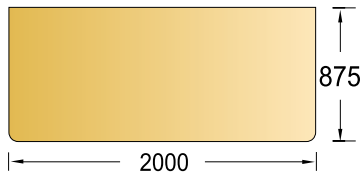
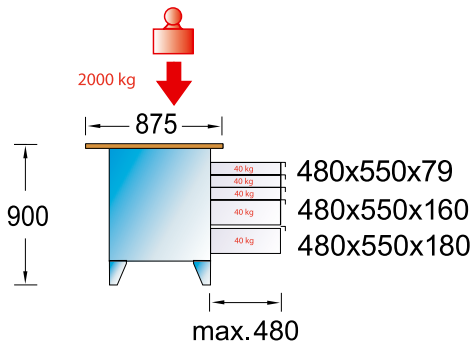

No. BR 1500 LH

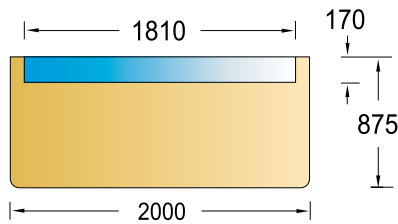

Code	No.	mm	H	W	D	
6618210	BR 1500 LH	40	1790	2000	875	203.7
6618050	B 1500 L	40	900	2000	875	166.0

R 1500 L



40





ACCESSORIES FOR WORKBENCHES

R 1504 L

REAR PANEL

- ✔ Can be attached to workbench 1504 or 1505
- ✔ Automatically raised by two gas springs, lockable with cylinder lock
- ✔ Neat arrangement of tools
- ✔ Dimensions: H 640 x W 1000 x D 70 mm
- ✔ Execution LH with hook assortment No. 1504 HG
- ✔ GEDORIT blue

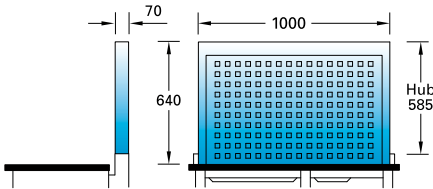

Code	No.	Description	H	W	D	→
6623800	R 1504 L	Rear panel empty, 640x1000x70 mm	640	1000	70	28.0
6624020	R 1504 LH	Rear panel empty with hook assortment, 640x1000x70 mm	640	1000	70	21.0

www.gedore.com

R 1504 XL-L

REAR PANEL

- ✔ Can be attached to workbench 1504 XL
- ✔ Automatically raised by two gas springs, lockable with cylinder lock
- ✔ Neat arrangement of tools
- ✔ Dimensions: W 1190 x D 70 mm
- ✔ GEDORIT blue
- ✔ Execution LH with hook assortment No. 1504 HG

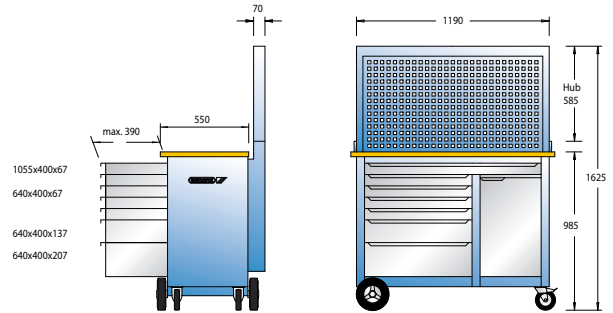

1504XL-0511 + R1504XL

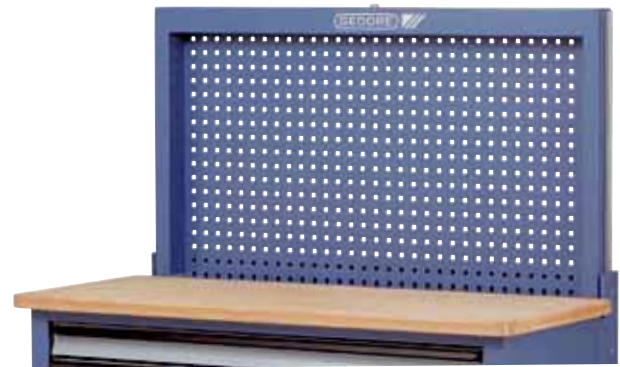

Code	No.	Description	H	W	D	→
2251787	R 1504 XL-L	Rear panel empty, 640x1190x70 mm	640	1190	70	
2251795	R 1504 XL-LH	Rear panel empty with hook assortment, 640x1190x70 mm	640	1190	70	

FOLDING WORKBENCH

B 1525

FOLDING WORKBENCH

- ✔ Stable hinged workbench, needs little space when folded
- ✔ Strong beech wood worktop with zinc-plated steel edge protector - corrosion resistant
- ✔ Base made from steel tube, in GEDORIT blue
- ✔ Load capacity 500 kg
- ✔ Dimensions: H 810 x W 1000 x D 700 mm

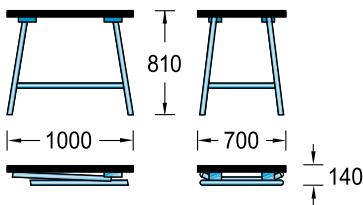

Code	No.	mm	H	W	D	→
6622910	B 1525	30	810	1000	700	32.0



WORKBENCHES SELF-ASSEMBLY RANGE

B 1510 - B 1511

WORKBENCH WITH DRAWER CABINET

- 40 mm thick multiplex beech wood worktop
- With 1 to 4 drawers, front panel height 90 mm
- Drawer dimensions: W 480 x D 535 x H 75 mm
- Drawers fully extendable, removable
- Individually partitionable, delivery includes length- and crosswise dividers
- Load capacity per drawer 35 kg
- Drawer cabinet can be mounted either right or left
- Central locking with cylinder lock
- Workbench stands made from U-steel section and includes floor mounting plate
- Load capacity 250 kg evenly distributed
- In GEDORIT blue, drawers GEDORIT silver
- Delivery disassembled, for self-assembly, mounting material included
- Dimensions: **B 1510**: H 840 x W 1500 x D 700 mm / **B 1511**: H 840 x W 2000 x D 700 mm

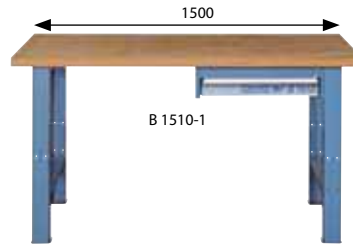

B 1510-1

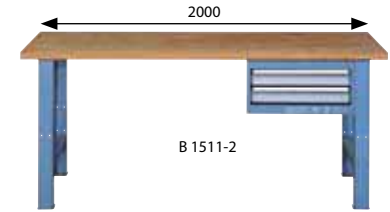

B 1511-2

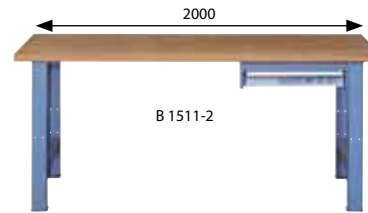

B 1511-2

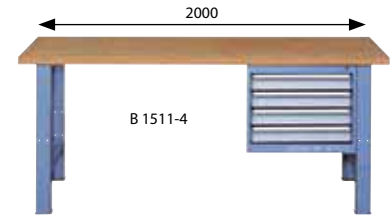

B 1511-4

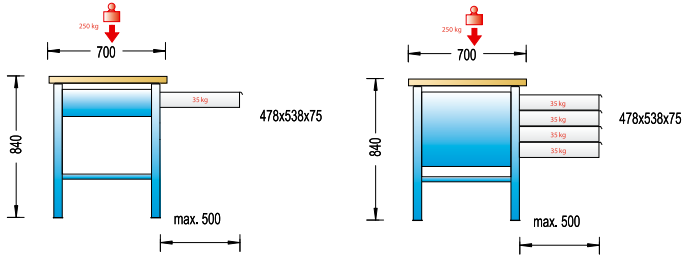

Code	No.	Execution	H	W	D	Weight
1955713	B 1510-1	1 90	840	1500	700	59.0
1955764	B 1511-1	1 90	840	2000	700	69.0
1955772	B 1511-2	2 90	840	2000	700	78.0
1955799	B 1511-4	4 90	840	2000	700	96.0

DRAWER CABINETS

1405

DRAWER CABINET

- Drawers fully extendable
- With mechanical interlock system that allows only one drawer to open at a time
- Drawer size inside: 612 x 612 mm
- Central locking with cylinder lock
- Dimensions: H 1000 x W 697 x D 695 mm
- In GEDORIT blue, drawers GEDORIT silver



1405-5

1405-7



1405-8



1405-10

Code	No.	Execution	H	W	D	Weight
1958224	1405-5	5 3x 150 2x 225	1000	697	695	88.0
1958232	1405-7	7 3x 75 3x 150 1x 225	1000	697	695	100.0
1958240	1405-8	8 4x 75 4x 150	1000	697	695	106.0
1958259	1405-10	10 8x 75 2x 150	1000	697	695	118.0

TOOL CABINETS

1400

TOOL CABINET

- ✔ Sturdy sheet steel construction with storage and three drawers
- ✔ With fittings for tool assortment S 1400
- ✔ Including loose modules 1500 E-1993 L and 1500 E-19 L
- ✔ With cylinder lock
- ✔ In GEDORIT blue, drawers GEDORIT silver
- ✔ Dimensions: H 970 x W 650 x D 250 mm



Code	No.	Compilation	H	W	D	Wt
6612600	1400 L	Cabinet empty	970	650	250	33.0
6613250	1400 GM	Cabinet 1400 L + assortment S 1400 GM	970	650	250	46.7
6613330	1400 GZM	Cabinet 1400 L + assortments S 1400 GM + ZM	970	650	250	57.4
6613410	1400 GA	Cabinet 1400 L + assortment S 1400 GA	970	650	250	46.6

1401

TOOL CABINET

- ✔ Sturdy sheet steel construction with perforated lining for any individual arrangement
- ✔ With storage and three drawers
- ✔ With loose modules 1500 E-1993 L and 1500 E-19 L
- ✔ With cylinder lock
- ✔ In GEDORIT blue, drawers GEDORIT silver
- ✔ Dimensions: H 970 x W 650 x D 250 mm

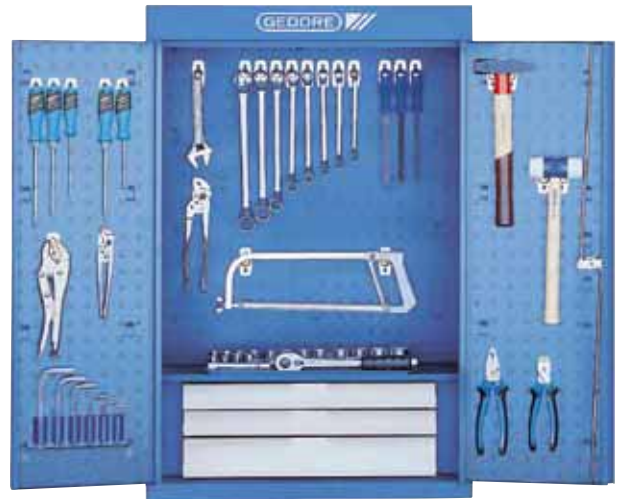

Code	No.	Compilation	H	W	D	Wt
5610610	1401 L	Cabinet empty	970	650	250	39.0
6611550	1401 LH	Cabinet 1401 L + hook assortment 1500 HS 11	970	650	250	34.0
6611630	1401 GM	Cabinet 1401 L + hook assortment 1500 HS 11 + assortment S 1400 GM	970	650	250	48.0
6611710	1401 GZM	Cabinet 1401 L + hook assortment 1500 HS 11 + assortments S 1400 GM + ZM	970	650	250	58.0
6611980	1401 GA	Cabinet 1401 L + hook assortment 1500 HS 11 + assortment S 1400 GA	970	650	250	47.0

R 1500 L

TOOL CABINET

- ✔ Suitable as workbench top
- ✔ Sheet steel construction
- ✔ With metal shutter lockable by cylinder lock
- ✔ Perforated rear to take fittings for any choice of assortment
- ✔ Model LH with hook assortment no. 1500 HS 23
- ✔ Dimensions: H 890 x W 1810 x D 170 mm
- ✔ In GEDORIT blue, shutter GEDORIT silver
- ✔ Delivery without tools



Code	No.	H	W	D	Wt
6617910	R 1500 L	890	1810	170	78.0
6619100	R 1500 LH	890	1810	170	81.2



B 1500 L

37



B 1450 LH / LHG



79
-
81



ACCESSORIES TOOL TROLLEYS / WORKBENCHES

1500 BL

LIGHT STRIP FOR TOOL TROLLEYS

- Light strip to provide ideal illumination of drawers, particularly on GEDORE tool trolleys
- A magnetic strip securely attaches the lighting to the trolley body
- Positioned above the drawers, the ten powerful LEDs illuminate the opened drawers
- This makes it easier to locate the right tool in dark or low lighting conditions, preventing the risk of cuts from chisels, knives or saw blade
- The light strip is also suitable for use on folding back panels and tool chests
- Easy battery change (three AAA batteries)
- LED technology for low power consumption and long life
- DBGM (German utility patent)
- The light strip can be used with the following GEDORE products: 2004, 2005, 2430, 2500, 3010, 2525, 2545, 2546, 2550, 2535, 3000, 1504, 1502, 1504 XL, R 1504, 1505, B 1500, R 1500, B 1510-1 to -4, 1405, 1400, 1401



Code	No.	(mm)	↕
2247542	1500 BL	430	280

1500 H 13

ANTI-SLIP MAT Products sold by the metre

- For all drawers in GEDORE tool trolleys and workbenches
- Various areas of application: Workshop, household, car, spare time...
- Enormous slip resistance on many different surfaces
- Can be cut to size
- Resistant to temperatures from -30°C to +100°C
- Melting point approx. +250°C
- Flame resistant
- Resistant to chemicals
- Shock- and noise absorbing
- Dimensions: W 475 x L 2000 mm



Code	No.	↕
5790250	1500 H 13	540

1500 H 15

WRITING SUPPORT

- For all GEDORE tool trolleys and workbenches
- Height adjustable with one swift movement
- Inclination adjustable, 4 x 90° swivel mounted for individual positioning
- Very robust for neat writing
- Keeps the working surface free
- Writing surface 310 x 400 mm
- Easy extendable, mounting material included in delivery
- Delivery without decoration

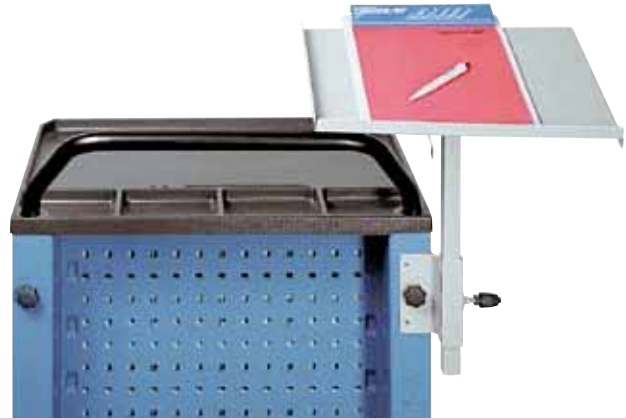

Code	No.	↕
5806860	1500 H 15	3.9

1500 H 16

SMALL-PARTS DRAWER FOR TOOL TROLLEYS

- To place on top of existing drawers of tool trolleys, additional surface to place small parts
- Suitable for tool trolleys and workbenches in combination with modules 1500 ES: 2003, 2500, 3000, B 1500, 1502, 1504, 1505
- Suitable for tool trolleys and workbenches without using modules 1500 ES: 1580, 2000, 3010
- Tool trolley 2004: suitable for drawer height 137 and 207 mm, for 67 mm not in combination with 1500 ES
- Delivery without decoration



Code	No.	↕
1761129	1500 H 16	644





E-1500 - E-3000

LENGTHWISE DIVIDER slotted

- ✔ In three different heights
- ✔ In seven different lengths for varying drawer depths
- ✔ In zinc-plated sheet steel

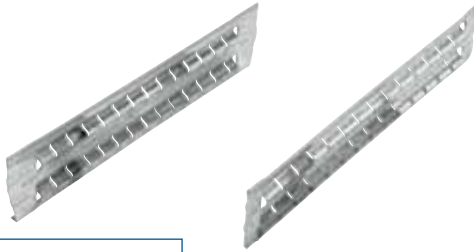

Code	No.	L	H	for use with	↕
5325840	E-1580/14	317	42	1580, 2000, 3010	136
5326570	E-2500/62	320	60	2500 (1-7), 1431 (1), 1430	190
5325920	E-3000/36	346	60	3000 (1-6)	204
1886932	E-2005 KL/42	395	60	2005, 1504 XL, 2430	235
5326490	E-1504 KL/57	397	60	1502 (1-5), 1504 (1-6), 2003 (1-6), 2004 (type 1)	208
2335239	E-2545/070	409	50	2545, 2546, 2550	200
5315880	E-B 1500/38	548	60	B 1500 (1-3), 1505 (1-3)	312

E-1580

CROSSWISE DIVIDER

- ✔ Usage: 1580, 2000, 3010
- ✔ In three different lengths, to fit the lengthwise dividers
- ✔ In zinc-plated sheet steel



Code	No.	L	H	↕
1394878	E-1580/11-40	40	40	12
5325760	E-1580/11-80	80	40	24
5326140	E-1580/11-120	120	40	36

E-2545 - E-3000

CROSSWISE DIVIDER

Usage:

- ✔ **E-3000:** 1430, 1431 (1), B 1500 (1-3), 1502 (1-5), 1504 (1-6), 1504 XL, 1505 (1-3), 2003 (1-6), 2004 (type 1), 2005 (type 1), 2430, 2500 (1-7), 3000
- ✔ **E-2545:** 2550 consisting of 2545 and 2546
- ✔ In zinc-plated sheet steel



Code	No.	L	H	↕
5326060	E-3000/37-80	80	55	35
5326220	E-3000/37-120	120	55	50
2335220	E-2545/99	99	50	100

TOOL HOLDERS / TOOL HOOKS

1500 H 0

TOOL HOOK straight mandrel

- ✔ Ø 4 mm especially suitable for GEDORE screwdrivers with hanging hole
- ✔ Suitable for perforated panels with square perforation 9 x 33 mm and 10 x 38 mm
- ✔ Chrome-plated



Code	No.	Ø	l-mm	↕	↔
5803410	1500 H 0-50	4	50	28	10

1500 H 1

TOOL HOOK inclined hook end

- ✔ Suitable for perforated panels with square perforation 9 x 33 mm and 10 x 38 mm
- ✔ Chrome-plated



Code	No.	Ø	l-mm	↕	↔
5803680	1500 H 1-50	4	50	28	10

1500 H 2 - 1500 H 3

SPRING CLAMP

- ✔ Suitable for perforated panels with square perforation 9 x 33 mm and 10 x 38 mm
- ✔ Chrome-plated



H2



H3



Code	No.	Ø	l-mm	↕	↔
2008351	1500 H 2-10	10	31	25	10
5803760	1500 H 2-13	13	31	26	10
2008378	1500 H 2-16	16	31	27	10
5803840	1500 H 3	20-35	44	28	10

**1500 H 4****BASE PLATE**

- With M6 thread for universal fixing
- Suitable for perforated panels with square perforation 9 x 33 mm and 10 x 38 mm
- Chrome-plated



Code	No.	W	H	D	Icons
1446185	1500 H 4	26	10		

1500 H 9**TRAY**

- A handy place to keep tools that are needed constantly
- 1500 H 9-75 can be fitted in connection with door element 1500 H 14



Code	No.	W	H	D	Icons
1446924	1500 H 9-75	456	50	75	854
5792540	1500 H 9-100	456	50	100	854

1500 H 5**PAPER ROLL HOLDER**

- Suitable for perforated panels with square perforation 9 x 33 mm and 10 x 38 mm



Code	No.	W	H	D	Icons
5798660	1500 H 5	250	6	94	1

1500 H 6**CABLE REEL HOOK**

- Suitable for perforated panels with square perforation 9 x 33 mm
- Delivery without decoration



Code	No.	W	H	D	Icons
5797850	1500 H 6	110	40	60	95 1

1500 H 8**HOLDER**

Code	No.	W	H	D	Icons
5792460	1500 H 8	456	5	150	

1500 H 10**TRAY**

- With four partitions, for often-needed small parts
- 1500 H 10-75 can be fitted in connection with door element 1500 H 14



Code	No.	W	H	D	Icons
1446932	1500 H 10-75	456	50	75	766
5792620	1500 H 10-100	456	50	100	840

3000 TANTO

23

1500 H 11**TRAY**

- With 4 plastic cases 1500 H-11/3, for holding larger quantities of working materials
- Cannot be fitted in connection with door element 1500 H 14



Code	No.	W	H	D	Icons
5792700	1500 H 11	456	55	95	655

1500 H 18**TOOL HOOK straight mandrel**

- Suitable for perforated panels with square perforation 9 x 33 mm and 10 x 38 mm
- Delivery without tools



Code	No.	Ø	W	H	D	Icons
2008386	1500 H 18-50	6	50	34	10	
2008394	1500 H 18-100	6	100	46	10	
2008408	1500 H 18-150	6	150	56	10	

1500 H 19**TOOL HOLDER double, straight mandrel**

- Suitable for perforated panels with square perforation 9 x 33 mm
- Delivery without tools



Code	No.	Ø	W	H	D	Icons
2008416	1500 H 19-50	6	50	74	5	
2008424	1500 H 19-100	6	100	98	5	
2008432	1500 H 19-150	6	150	118	5	





1500 H 20

- TOOL HOLDER vertical hook end**
- ✔ Suitable for perforated panels with square perforation 9 x 33 mm and 10 x 38 mm
 - ✔ Chrome-plated
 - ✔ Delivery without decoration

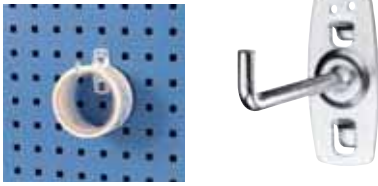

Code	No.	Ø	H	W	D
1879162	1500 H 20-35	6	35	34	10
2008440	1500 H 20-75	6	75	46	10
2008459	1500 H 20-135	6	135	56	10

1500 H 21

- TOOL HOLDER double, vertical hook end**
- ✔ For hammers and ratchets
 - ✔ Suitable for perforated panels with square perforation 9 x 33 mm
 - ✔ Chrome-plated
 - ✔ Delivery without tools

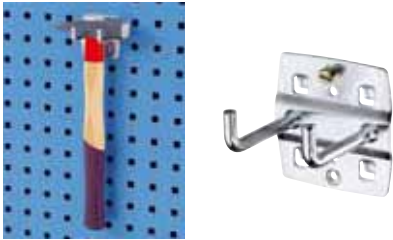

Code	No.	Ø	H	W	D
2008475	1500 H 21-35	6	35	76	5
1879170	1500 H 21-50	6	50	80	5
2008483	1500 H 21-75	6	75	90	5

1500 H 22

- TOOL HOLDER for pliers**
- ✔ Suitable for perforated panels with square perforation 9 x 33 mm
 - ✔ Chrome-plated
 - ✔ Delivery without tools

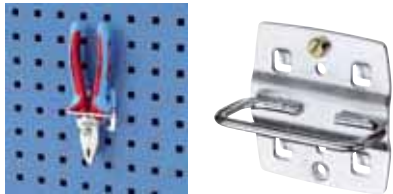

Code	No.	W	D	H	D
2008491	1500 H 22-35	35	20	62	5
1879189	1500 H 22-55	55	20	66	5
2008505	1500 H 22-75	75	20	68	5

1500 H 23

- MACHINE HOLDER FOR BATTERY SCREWDRIVER**
- ✔ Suitable for perforated panels with square perforation 9 x 33 mm
 - ✔ Chrome-plated
 - ✔ Delivery without tools

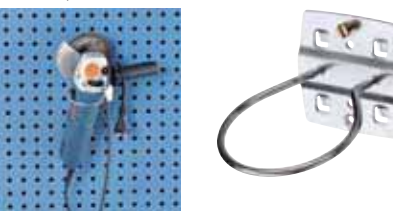

Code	No.	Ø	H	D
2008513	1500 H 23-40	40	68	5
1879197	1500 H 23-60	60	60	5
2008521	1500 H 23-80	80	80	5

1500 H 24

- TOOL HOLDER for screwdrivers**
- ✔ Suitable for perforated panels with square perforation 9 x 33 mm
 - ✔ Chrome-plated
 - ✔ Delivery without tools

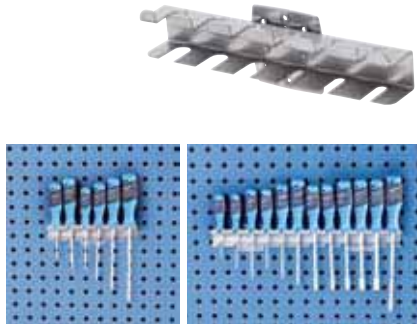

Code	No.	Execution	W	D
1879200	1500 H 24-6	for 6 pieces	100	1
2008548	1500 H 24-12	for 12 pieces	400	1

1500 H 25

- TOOL HOLDER for 3 cans**
- ✔ Suitable for perforated panels with square perforation 9 x 33 mm
 - ✔ Chrome-plated
 - ✔ Delivery without decoration



Code	No.	Ø	W	H	D
2008556	1500 H 25-1	70	100	200	1
1879219	1500 H 25-3	70	300	600	1

1500 H 26

- MOUNTING RAIL FOR STORAGE BOXES**
- ✔ Suitable for perforated panels with square perforation 9 x 33 mm
 - ✔ No. 1500 H 26-1 for one storage box (max. 105 mm wide)
 - ✔ No. 1500 H 26 for up to 4 storage boxes (depending on width)
 - ✔ Delivery without storage boxes



Code	No.	H	W	D
2008564	1500 H 26-1	55	50	5
1933183	1500 H 26	495	418	1

1500 H 27

- SOCKET HOLDER**
- ✔ With 11 holes
 - ✔ Hole diameter 10x 25 mm and 1x 27.5 mm
 - ✔ Suitable for perforated panels with square perforation 9 x 33 mm
 - ✔ Delivery without tools



Code	No.	W	H	D	H	D
1920634	1500 H 27	352	60	54	500	1

1500 H 28

- SHELF**
- ✔ Suitable for perforated panels with square perforation 9 x 33 mm



Code	No.	W	H	D	H	D
1933191	1500 H 28	496	168	303	3000	1

1500 H 29

- TOOL HOOK inclined hook end**
- ✔ Suitable for perforated panels with square perforation 9 x 33 mm and 10 x 38 mm
 - ✔ Delivery without tools

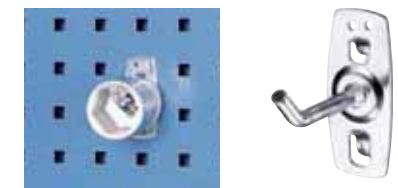

Code	No.	Ø	H	W	D
2008572	1500 H 29-50	6	50	34	10
2008580	1500 H 29-100	6	100	46	10





1500 H 30

TOOL HOOK for sockets

- ✔ Suitable for perforated panels with square perforation 9 x 33 mm and 10 x 38 mm

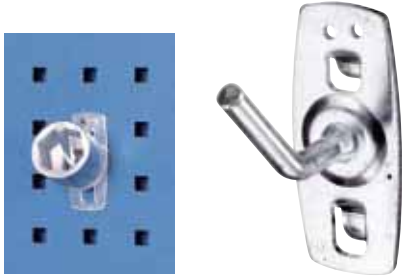

Code	No.	L ₁	L ₂	Ø	↳	↳
2008599	1500 H 30	15	40	6	34	10

1500 H 31

ROUND HOLDER

- ✔ Suitable for perforated panels with square perforation 9 x 33 mm
- ✔ Delivery without tools



Code	No.	W	L	↳	↳
2008602	1500 H 31	27	65	68	5

1500 H 32

SAW HOLDER

- ✔ Suitable for perforated panels with square perforation 9 x 33 mm
- ✔ For 4 saws. Please order in pairs!
- ✔ Delivery without tools



Code	No.	D	H	↳	↳
2008610	1500 H 32	80	52	86	1

1500 H 33

TUBE HOLDER

- ✔ Suitable for perforated panels with square perforation 9 x 33 mm
- ✔ Hook width 35 mm
- ✔ Delivery without decoration

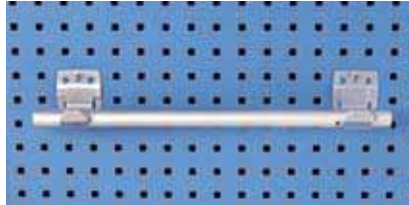

Code	No.	W	H	D	Ø	↳	↳
2008629	1500 H 33-60	58	67	74	60	114	1
2008637	1500 H 33-100	58	96	114	100	156	1

1500 H 34

DRILL-BIT HOLDER

- ✔ Suitable for perforated panels with square perforation 9 x 33 mm
- ✔ No. **1500 H 34-14** with 14 holes, diam.:
2 ea. 3.0 4.2 6.5 7.5 8.5 16.5 mm, 1 ea. 10.5 12.5 mm
- ✔ No. **1500 H 34-28** with 28 holes, diam.:
4 ea. 3.2 4.2 6.5 7.5 8.5 16.5 mm, 2 ea. 10.5 12.5 mm
- ✔ Delivery without tools

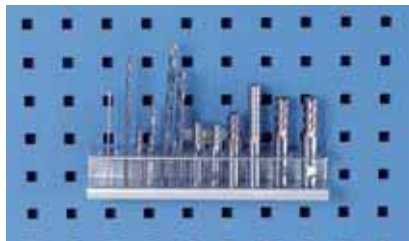

Code	No.	W	H	D	↳	↳
2008645	1500 H 34-14	200	60	37	200	1
2008653	1500 H 34-28	390	60	37	400	1

1500 H 35

HOLDER FOR ALLEN KEYS

- ✔ Suitable for perforated panels with square perforation 9 x 33 mm



Code	No.	W	H	↳	↳
2008661	1500 H 35	200	73	300	1

1500 H 36

TOOL HOLDER

- ✔ For customising (wooden plate)
- ✔ Suitable for perforated panels with square perforation 9 x 33 mm
- ✔ Delivery without tools



Code	No.	W	H	D	↳	↳
2008688	1500 H 36	340	55	135	1100	1

1500 H 37 - 1500 H 38

SPANNER HOLDER

- ✔ Suitable for perforated panels with square perforation 9 x 33 mm
- ✔ No. **1500 H 37**: for 8 spanners, suitable for no. 1 B, 2, 4, 6, 7, 7 R
- ✔ No. **1500 H 38**: for 10 spanners, suitable for no. 2, 6
- ✔ Delivery without tools



Code	No.	W	H	D	↳	↳
2008696	1500 H 37	124	66	145	220	1
1920626	1500 H 38	75-147	227	60	400	1



VH 1

TOOL HOLDER EMPTY for 8 spanners

- With handle, transport safety device (anti-theft device) and self-service suspension
- Suitable for the sets 1 B-080, 4-8, 6-8, and 7-080 as well for 7 R and 7 UR
- Delivery without tools



Code	No.	W	H	D	Icon 1	Icon 2
1465147	VH 1				74	1



WVH 1

TOOL HOLDER EMPTY for 8 spanners

- Can be fixed firmly to various wall types, e.g. EURO-perforation panels, GEDORE perforation panels, wooden and stone walls
- Includes base support WH 1, tool holder VH 1 and two distance washers for fixing to wooden walls
- Suitable for the sets 1 B-080, 4-8, 6-8, and 7-080 as well as 7 R and 7 UR
- Delivery without tools



Code	No.	Description	W	H	D	Icon 1	Icon 2
1465120	WVH 1	Wall holder complete, empty				276	1
1465155	WH 1	Base support				116	1
1476386	WH 1 S	Base support with distance washers				160	1
1465171	E-WVH 1/4	Distance washers for WVH 1				20	1

VS 19 H

TOOL TRAY

- For sockets
- Dimensions: W 570 x D 25-45 mm
- In sheet steel, GEDORIT blue



Code	No.	W	D	W	H	D	Icon 1	Icon 2
5152640	VS 19 H	570	25-45	550				1

VS 245 H

CHISEL HOLDER EMPTY

- For 6 chisels
- Dimensions: W 195 x H 95 x D 22 mm
- In sheet steel, GEDORIT blue



Code	No.	W	H	D	W	H	D	Icon 1	Icon 2
5456270	VS 245 H	195	95	22	300				1

VS 1500 H

GENERAL PURPOSE BOX

- Dimensions: H 330 x W 230 x D 100/120 mm



Code	No.	W	H	D	Icon 1	Icon 2
5797770	VS 1500 H				1500	

VS 1582

STORAGE TRAY



Code	No.	Description	H	W	D	W	H	D	Icon 1	Icon 2
5150000	VS 1582-1	Storage tray 50x320x150 mm	50	320	150	1016				1
5150190	VS 1582-2	Tray for drawings 150x320x50 mm	150	320	50	1270				1
5150270	VS 1582-3	Storage tray 100x320x90 mm	100	320	90	1118				1

H 6

HOLDER

- For double open ended spanner sets no. 6
- Suitable for perforated panels with square perforation 9 x 33 mm



E-PH 6



H 6-8 L



H 6-12 L



H 6-8 B



H 6-12 B

Code	No.	Description	W	H	D	W	H	D	Icon 1	Icon 2
5079110	H 6-8 B	Sheet metal holder, empty for 8 spanners no. 6	390	140	15	372				1
5079540	H 6-12 B	Sheet metal holder, empty for 12 spanners no. 6	600	170	15	655				1
5070080	H 6-8 L	Plastic holder, empty for 8 spanners no. 6	250	70	57	154				1
5070160	H 6-12 L	Plastic holder, empty for 12 spanners no. 6	325	100	57	270				1
5073930	E-PH 6-8 L	Plastic holder, empty for 8 spanners no. 6				18				1
5074070	E-PH 6-12 L	Plastic holder, empty for 12 spanners no. 6				38				1



1500 HS						
HOOK ASSORTMENT						
<ul style="list-style-type: none"> Suitable for perforated panels with square perforation 9 x 33 mm 						
Code	No.	Contents	Use			
5802870	1500 HS 1	4x 1500 H 0-50 18x 1500 H 1-50 1x H 6-8 B 1x VS 245 H	S 1005 A S 1151 M S 1151 A	1540	1	
5802950	1500 HS 2	23x 1500 H 1-50 6x 1500 H 2-13 2x VS 245 H	S 1002 M	1000	1	
5803090	1500 HS 3	7x 1500 H 0-50 24x 1500 H 1-50 2x 1500 H 2-13 2x 1500 H 3 1x VS 245 H	S 1004 M S 1005 A	1110	1	
5803170	1500 HS 4	4x 1500 H 0-50 17x 1500 H 1-50 6x 1500 H 3 1x VS 245 H	S 1006 M	870	1	
5803250	1500 HS 5	12x 1500 H 0-50 20x 1500 H 1-50 1x 1500 H 38 1x VS 245 H	S 1400 GM S 1400 GA S 1400 GZA	2334	1	
5803330	1500 HS 6	7x 1500 H 0-50 25x 1500 H 1-50 1x VS 245 H	S 1011 M	1386	1	
5803920	1500 HS 7	12x 1500 H 0-50 22x 1500 H 1-50 3x 1500 H 2-13 3x 1500 H 3 1x VS 245 H	S 1009 M	1260	1	
5805460	1500 HS 8	14x 1500 H 0-50 18x 1500 H 1-50 1x H 6-12 B	S 1007 M S 1008 M S 1013 M	1510	1	
5805540	1500 HS 9	4x 1500 H 0-50 16x 1500 H 1-50 1x H 6-8 B 1x VS 245 H		1524	1	
5805620	1500 HS 10	9x 1500 H 0-50 25x 1500 H 1-50 2x 1500 H 2-13 1x 1500 H 3 1x VS 245 H	S 1004 M	1648	1	
5799980	1500 HS 11	14x 1500 H 0-50 23x 1500 H 1-50 1x 1500 H 2-13 2x 1500 H 3 1x 1500 H 38 1x VS 245 H	S 1400 GM S 1400 GA S 1400 GZA	2680	1	
5805700	1500 HS 12	12x 1500 H 0-50 25x 1500 H 1-50 3x 1500 H 2-13 3x 1500 H 3 1x VS 245 H	S 1009 M	1846	1	
5805890	1500 HS 13	16x 1500 H 0-50 19x 1500 H 1-50 3x 1500 H 2-13 2x 1500 H 3 1x H 6-12 B 1x VS 245 H	S 1008 M	2234	1	
5802010	1500 HS 14	6x 1500 H 0-50 20x 1500 H 1-50 6x 1500 H 2-13 1x 1500 H 3 1x H 6-8 B 1x VS 245 H 1x VS 19 H	S 1151 M S 1151 A	2388	1	
5805970	1500 HS 15	25x 1500 H 1-50 9x 1500 H 2-13 1x 1500 H 3 2x VS 245 H 1x VS 19 H	S 1002 M	1570	1	
5806510	1500 HS 16	7x 1500 H 0-50 29x 1500 H 1-50 5x 1500 H 2-13 3x 1500 H 3 1x VS 245 H 1x VS 19 H	S 1004 M	2330	1	
5804060	1500 HS 17	15x 1500 H 0-50 32x 1500 H 1-50 4x 1500 H 2-13 2x 1500 H 3 1x 1500 H 27 1x 1500 H 38 2x VS 245 H 1x VS 19 H	S 1400 GM, S 1400 GA	3514	1	
5807160	1500 HS 18	12x 1500 H 0-50 32x 1500 H 1-50 4x 1500 H 2-13 4x 1500 H 3 1x VS 245 H 2x VS 19 H		3008	1	
5809370	1500 HS 19	4x 1500 H 0-50 28x 1500 H 1-50 3x 1500 H 2-13 7x 1500 H 3 2x VS 245 H 1x VS 19 H		2584	1	
5860050	1500 HS 20	7x 1500 H 0-50 47x 1500 H 1-50 2x 1500 H 3 1x VS 245 H	S 1011 M	1740	1	

Code	No.	Contents	Use			
5860130	1500 HS 21	15x 1500 H 0-50 35x 1500 H 1-50 5x 1500 H 2-13 2x 1500 H 3 1x H 6-12 B 1x VS 19 H		3134	1	
5860210	1500 HS 22	5x 1500 H 0-50 38x 1500 H 1-50 3x 1500 H 2-13 8x 1500 H 3 1x VS 245 H 2x VS 19 H	S 1006 M	3068	1	
5804220	1500 HS 23	17x 1500 H 0-50 43x 1500 H 1-50 12x 1500 H 2-13 10x 1500 H 3 1x 1500 H 27 1x 1500 H 38 2x VS 245 H 1x VS 19 H	S 1400 GZA	4958	1	
5860480	1500 HS 24	11x 1500 H 0-50 42x 1500 H 1-50 6x 1500 H 2-13 4x 1500 H 3 1x VS 245 H 2x VS 19 H	S 1009 M	3620	1	
5860560	1500 HS 25	20x 1500 H 0-50 42x 1500 H 1-50 5x 1500 H 2-13 3x 1500 H 3 1x H 6-12 B 2x VS 245 H 1x VS 19 H	S 1007 M S 1008 M S 1013 M	3170	1	
2008726	1500 HS 26	3x 1500 H 29-100 4x 1500 H 20-35 3x 1500 H 21-35 1x 1500 H 22-35 1x 1500 H 23-40		616	1	
2008734	1500 HS 27	2x 1500 H 2-10 1x 1500 H 2-13 2x 1500 H 20-75 2x 1500 H 21-35 1x 1500 H 21-50 2x 1500 H 22-55 1x 1500 H 24-6 5x 1500 H 29-50 1x 1500 H 34-14 1x 1500 H 37		1322	1	
2008742	1500 HS 28	4x 1500 H 20-35 2x 1500 H 20-75 2x 1500 H 20-135 6x 1500 H 21-35 2x 1500 H 22-35 1x 1500 H 23-40 1x 1500 H 24-6 3x 1500 H 29-50 3x 1500 H 29-100 2x 1500 H 31 1x 1500 H 34-14 1x 1500 H 37		1768	1	
5802440	1504 HG	13x 1500 H 0-50 13x 1500 H 1-50 1x H 6-12 B 2x VS 245 H	R 1504 LH BR 1504 0511 LH BR 1504 0511 S	1958	1	
5801550	1582 HG	10x 1500 H 1-50 5x 1500 H 2-13 5x 1500 H 3		654	1	

STAND ASHTRAY

1500 ST

STAND ASHTRAY

- Sturdy design in powder-coated sheet steel
- Convenient apertures for larger litter on three sides
- Ashtray insert in sheet steel



Code	No.	L	W	H		
1531468	1500 ST	200	200	630	5.1	1



TOOL BOXES

- ✔ With riveted joints
- ✔ Compartments to be fully pulled out
- ✔ Great stability even if only one side is opened
- ✔ In GEDORIT blue
- ✔ Tools not supplied

1263

TOOL BOX 3 compartments

- ✔ With riveted joints
- ✔ Compartments to be fully pulled out
- ✔ Great stability even if only one side is opened
- ✔ GEDORIT blue powder-coated
- ✔ Dimensions: H 158 x W 420 x D 225 mm
- ✔ Particularly suitable for tool assortments S 1151 M and S 1151 A
- ✔ Delivery without tools

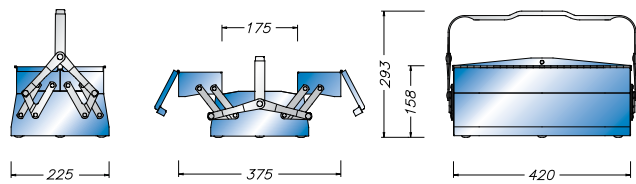
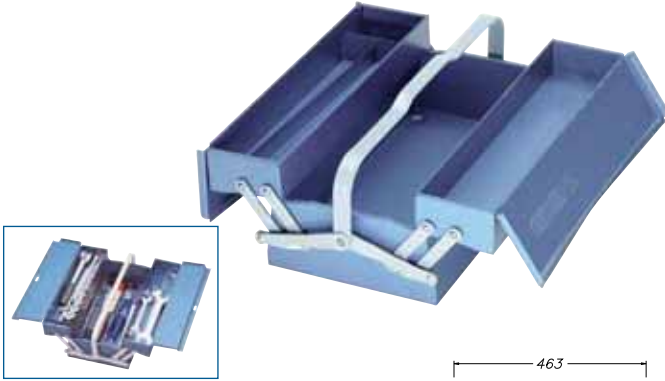

Code	No.	Compilation	H	W	D	Weight
6608250	1263 L	Tool box empty	158	420	225	4.0
6608330	1263-1151 M	Tool box 1263 L + assortment S 1151 M	158	420	225	15.8
6608410	1263-1151 A	Tool box 1263 L + assortment S 1151 A	158	420	225	15.8

1265

TOOL BOX 5 compartments

- ✔ With riveted joints
- ✔ Compartments to be fully pulled out
- ✔ Great stability even if only one side is opened
- ✔ GEDORIT blue powder-coated
- ✔ Dimensions: H 210 x W 420 x D 225 mm
- ✔ Particularly suitable for tool assortments S 1151 M and S 1151 A
- ✔ Delivery without tools

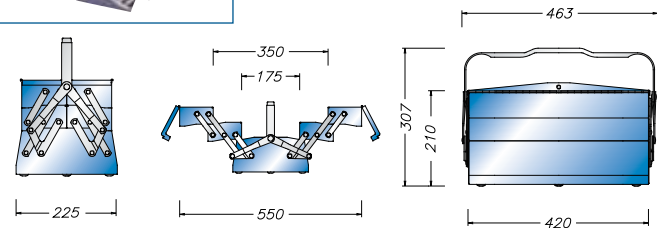
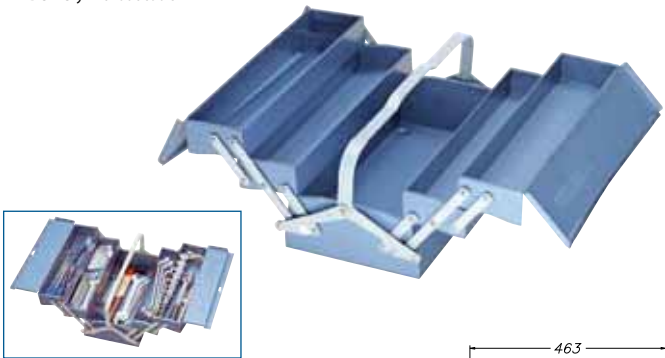

Code	No.	Compilation	H	W	D	Weight
6609060	1265 L	Tool box empty	210	420	225	5.2
6609140	1265-1151 M	Tool box 1265 L + assortment S 1151 M	210	420	225	17.3
6609220	1265-1151 A	Tool box 1265 L + assortment S 1151 A	210	420	225	17.3

1335

TOOL BOX 5 compartments, long pattern

- ✔ With riveted joints
- ✔ Compartments to be fully pulled out
- ✔ Great stability even if only one side is opened
- ✔ GEDORIT blue powder-coated
- ✔ Dimensions: H 210 x W 535 x D 225 mm
- ✔ Particularly suitable for tool assortments S 1151 M and S 1151 A
- ✔ Delivery without tools

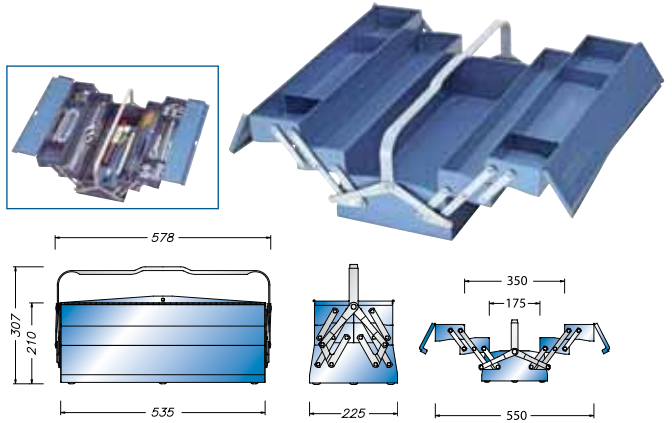

Code	No.	Compilation	H	W	D	Weight
6610580	1335 L	Tool box empty	210	535	225	6.3
6610660	1335-1151 M	Tool box 1335 L + assortment S 1151 M	210	535	225	18.5
6610740	1335-1151 A	Tool box 1335 L + assortment S 1151 A	210	535	225	18.5

Tool boxes

- ✔ Made of electrolytically zinc-plated sheet steel and therefore suitable for outdoors

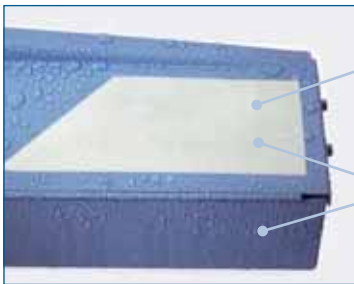

✔ As the zinc coating acts as a sacrificial anode, it protects should the other protective coating become damaged

✔ Optimum corrosion-proofing achieved with 2 protective coats, zinc and powder coating

Optional accessories

S 1151 M / S 1151 A



S 1151 M



S 1151 A



**68
77**

**TOOL CHESTS****1410 L****TOOL CHEST**

- With three large and three small drawers and carrying tray
- All drawers fully extendable on runners
- Made from sturdy sheet steel, fitted with central lock
- Particularly suitable for tool assortments S 1002 M and S 1005 A
- In GEDORIT blue, drawers GEDORIT silver
- Dimensions: H 364 x W 663 x D 308 mm
- Delivery without tools



Code	No.	H	W	D	
6614300	1410 L	364	663	308	28.0

1420 L**TOOL CHEST**

- With three large drawers and carrying tray
- All drawers fully extendable on runners
- Made from sturdy sheet steel, fitted with central lock
- Particularly suitable for tool assortments S 1002 M and S 1005 A
- In GEDORIT blue, drawers GEDORIT silver
- Dimensions: H 298 x W 610 x D 265 mm
- Delivery without tools



Code	No.	H	W	D	
6615700	1420 L	298	610	265	20.0

Optional accessories**S 1002 M****69****S 1005 A****77****TOOL BOXES****1072 ES****TOOL MODULE EMPTY**

- For tool modules 1500 ES
- May be individually equipped with two or three tool modules
- Foam rubber firmly glued to lid
- Suitable as spare part in tool chest 1433 L
- Sturdy sheet steel, in GEDORIT blue
- Dimensions: W 478 x D 313 x H 70 mm
- Delivery without tools



Code	No.	W	D	H	
6602990	1072 ES-1500 L	480	330	70	3.3

1370 Z**TOOL BOX**

- In special zinc-plated sheet steel for optimum protection against corrosion
- The manufacture using pressure-joint technology means great rigidity
- With removable small-parts compartment ES 1370 Z
- Fitted with carrying strap E-1370 in nylon fabric with shoulder protector
- Delivery without tools



Code	No.	H	W	D	
1497677	1370 Z	224	554	201.5	5.0
1497634	ES 1370 Z	69	179	167.0	0.6
5600300	E-1370				0.1

1072 K**TOOL BOX**

- Sturdy sheet steel, in GEDORIT blue
- With deep-drawn plastic insert with 19 compartments
- Fits into tool chest 1433 L
- Dimensions: W 480 x D 330 x H 70 mm
- (Ill. similar)



Code	No.	W	D	H	
1920049	1072 K-19	480	330	70	3.6

www.gedore.com



1440 Z

TOOL BOX JUMBO zinc-plated

- ✔ In special zinc-plated sheet steel for the heavy everyday-use
- ✔ Optimum corrosion protection, spray water protected
- ✔ Manufactured in pressure jointing technique, guarantees highest sturdiness
- ✔ Robust metal fittings and protected hinges
- ✔ Stopper to hold the lid open
- ✔ Wide carrying handles
- ✔ Max. loading 150 kg
- ✔ Lockable through padlock
- ✔ Lined interior
- ✔ Removable tray for small parts (ES 1440)
- ✔ Delivery without tools



Code	No.	H	W	D	WZ
6628280	1440 Z-70	320	698	387	17.0
6628360	1440 Z-83	340	841	427	21.0
6629170	1440 Z-91	440	918	537	30.0
6629250	1440 Z-100	320	998	387	22.0

1441 Z

TRANSPORT FRAME zinc-plated

- ✔ In special zinc-plated sheet steel
- ✔ Makes the tool boxes JUMBO 1440 / 1440 Z mobile
- ✔ With 4 castors, 2 of them with brake
- ✔ Delivery dismantled, for self-assembly



Code	No.	H	W	D	WZ
1497766	1441 Z-70	135	697	386	4.9
1497774	1441 Z-83	135	840	426	5.4
1497782	1441 Z-91	135	917	536	6.0
1497790	1441 Z-100	135	997	386	5.8

1440

TOOL BOX JUMBO

- ✔ Sheet steel construction with strong handles (apart from 1440-45, 1440-64)
- ✔ In GEDORIT blue, waterproof
- ✔ Strong joints, handles and stopper to hold the lid open
- ✔ Special lining, with document partition and removable tray for small parts ES 1440 (available separately)
- ✔ Please order separately transport frame 1441 Z
- ✔ Special finishes available on request
- ✔ 1440-45 without small parts tray
- ✔ Supported load 1440-70, -83, -91, -100 up to 400 kg without using the fold-down handles. When lifting, static supporting power of the fold-down handles max. 150 kg



Code	No.	H	W	D	WZ
6612440	1440-45	230	450	230	4.0
6611040	1440-64	230	640	230	7.0
6616510	1440-70	320	698	387	19.0
6616780	1440-83	340	841	427	23.0
6616860	1440-91	440	918	537	32.0
6616940	1440-100	320	998	387	25.0
6611120	ES 1440-64				1.0
6616000	ES 1440-70				1.8
6616190	ES 1440-83				2.1
6616270	ES 1440-91				2.4
6616350	ES 1440-100				2.0

Optional accessories

S 1004 M

63

S 1006 M

71



TOOL CASES / ROLLER TOOL CASES

1014 L - 1015 L

ROLLER TOOL CASE

- Optionable available in silver (no. 1014 L) or black (no. 1015 L)
- 4x telescopic grip extending max. length: 1 metre
- Widely spaced wheels and large ball-bearing-mounted smooth-running wheels ensure the case can be pushed or pulled without tipping
- Frame made from aluminium profiles, body from tough, impact-resistant ABS
- When open, the case lid hinges lock in place to prevent unintentional closing
- Document partition in the lid
- The case body can be individually compartmentalised with lengthwise and crosswise dividers
- Equipped with push-fit compartments and the GEDORE "Cliptool system", enabling individualised arrangement of the tool holders
- Lockable with two tilt cylinder locks
- Internal dimensions: 470 x 210 x 360 mm
- Carrying capacity: 40 kg
- Tools not supplied



Code	No.	Colour	W	D	H	Wheels
1946315	1014 L	silver	470	360	210	6.8
1946323	1015 L	black	470	360	210	6.8

1016 L - 1018 L

TOOL CASE

- Frame made from aluminium profiles, body from tough, impact-resistant ABS
- When open, the case lid hinges lock in place to prevent unintentional closing
- Document partition in the lid
- The case body can be individually compartmentalised with lengthwise and crosswise dividers
- Equipped with push-fit compartments and the GEDORE "Cliptool system", enabling individualised arrangement of the tool holders
- Lockable with two tilt cylinder locks
- Ground slides ensure tilt-secure standing, and also protect sensitive surfaces
- Internal dimensions No. 1016 L: 460 x 165 x 310 mm
- Internal dimensions No. 1018 L: 470 x 180 x 360 mm
- Carrying capacity: 30 kg
- Tools not supplied



Code	No.	W	D	H	Wheels
1946331	1016 L	460	310	165	4.7
1946358	1018 L	470	360	180	5.1

@WORK



484
-
487

Optional accessories

S 1150 M • S1151 M



65
68



S 1150 M



S 1151 M

